

Lignatec

ecorisQ

## Using timber to counter natural hazards

Erosion | Landslide | Torrent | Avalanche



## Contents

---

This project was made possible by funding from:

---

### Key financial support

Swiss Federal Office for the Environment (FOEN), Timber Action Plan (*Aktionsplan Holz*)

---

### Financial support

International Association for Natural Hazard Risk Management ecorisQ  
Präventionsstiftung der Kantonalen Gebäudeversicherungen PS-FP (risk management foundation of cantonal building insurers)

---

### Additional support by

Forstunternehmer Schweiz FUS (association of Swiss forestry contractors)  
Fachleute Naturgefahren FAN (association of Swiss natural hazards experts)  
Schweizerischer Ingenieur- und Architektenverein SIA, Fachverein Wald (professional association of Swiss forestry experts)

---

### Non-material sponsorship

Schweizerischer Ingenieur- und Architektenverein SIA (Swiss Society of Engineers and Architects SIA)

---

### Project partners

Bern University of Applied Sciences BFH, School of Agricultural, Forest and Food Sciences HAFL  
Fachstelle für forstliche Bautechnik Fobatec (center for forestry construction technology)  
University of Natural Resources and Applied Life Sciences Vienna BOKU  
WSL-Institut für Schnee- und Lawinenforschung SLF (Institute for Snow and Avalanche Research)

---

### Private-sector partners

Caprez Ingenieure AG, Silvaplana  
Castagnostyle GmbH, Taverne  
fim – Kompetenz für Forst, Landwirtschaft und Garten, Uetendorf  
Forst Aletsch, Fieschertal  
Lindner Suisse GmbH, Wattwil

<b>Page</b>	<b>4</b>	<b>Foreword</b>
	<b>5</b>	<b>1 Introduction</b>
		1.1 From hazard prevention to integrated risk management
		1.2 Measures as part of the IRM framework
		1.3 From felled logs to soil and water bioengineering
	<b>9</b>	<b>2 Durability of wood as a building material</b>
		2.1 General considerations
		2.2 Biodegradation of wood
		2.3 Use classes
		2.4 External and internal influences on the durability of wood
		2.5 Durable timber species and their occurrence in the Swiss forest
		2.6 Criteria for the use of wood for hazard mitigation structures
		2.7 Case study of a series of check dams in a torrent
	<b>14</b>	<b>3 Standards and notes on the dimensioning of hazard mitigation structures made of round timber</b>
		3.1 General considerations
		3.2 Standardisation
		3.3 Standards for the determination of stresses
		3.4 Standards for the verification of type 1 and type 3 limit states
		3.5 Standards for the verification of type 2 limit state
	<b>17</b>	<b>4 Timber for erosion control</b>
		4.1 Processes and impacts
		4.2 Overview and function of erosion control structures
		4.3 Construction and application of erosion control structures made of wood
	<b>22</b>	<b>5 Timber for landslide control</b>
		5.1 Processes and impacts
		5.2 Overview and function of landslide control structures
		5.3 Construction and application of wooden stabilising structures
		5.4 Limits to the use of wooden structures
		5.5 Complementary effect of bioengineering construction measures
	<b>33</b>	<b>6 Timber for torrent control</b>
		6.1 Processes and impacts
		6.2 Overview and function of dam structures
		6.3 Construction and application of wooden dam structures
		6.4 Construction of longitudinal structures made of wood
		6.5 Limits to the use of wooden structures
	<b>43</b>	<b>7 Timber for protection against avalanches and snow movements</b>
		7.1 Processes and impacts
		7.2 Overview and function of avalanche protection structures
		7.3 Construction and application of avalanche protection structures made of wood
		7.4 Snowdrift fences
		7.5 Limits to the use of wooden structures

---

**Authors**

Luuk Dorren, Prof. Dr., BFH-HAFL  
(Chapter 1)  
 Willy Eyer, Dipl.-Ing. ETH (Chapter 9)  
 Stefan Margreth, Dipl.-Ing. ETH, SLF  
(Chapter 3/7)  
 Gunther Ratsch, MSc Ing. BFH, Lignum  
(Chapter 3)  
 Christian Rickli, Dipl.-Ing. ETH, WSL  
(Chapter 2)  
 Massimiliano Schwarz, Dr., BFH-HAFL  
(Chapter 4/5)  
 Jürgen Suda, Dipl. Ing. Dr. rer. nat.,  
 BOKU (Chapter 3/6)  
 Magdalena Von Der Thannen,  
 Dipl.-Ing. Dr. techn., BOKU (Chapter 8)

---

**Specialist editors**

Willy Eyer, Dipl.-Ing. ETH  
 Franz Thalmann, Förster HF

---

**Coordination**

Gunther Ratsch, MSc Ing. BFH,  
 Lignum, Zurich (Editor-in-chief)  
 Hervé Bader, Dipl.-Ing. ETH, Fobatec  
 Walter Krättli, Bsc Forstwirtschaft BFH,  
 Fobatec

---

**Translation**

Translation Bureau for Environmental  
 Sciences, Seeheim-Jugenheim

---

**Cover image**

Snow rake made of timber,  
 a temporary avalanche control  
 structure in the Aletsch forest  
 (C. Pfammatter, Visp)

<b>52</b>	<b>8</b>	<b>Protective structures and sustainability</b>
	8.1	Introduction
	8.2	Standards and datasets
	8.3	Life cycle assessment of torrent control structures – a case study
	8.4	Findings
	8.5	Conclusions
<b>60</b>	<b>9</b>	<b>Overall conclusions</b>
	9.1	Advantages of using timber for protective structures
	9.2	Drawbacks of using timber for protective structures
	9.3	Weighing the pros and cons of timber use
<b>64</b>	<b>10</b>	<b>Partners</b>
<b>65</b>	<b>11</b>	<b>References</b>

## Foreword

---

Natural hazards pose a threat to people, property and the environment in Switzerland. Particularly significant in the context of this publication are gravitational hazards (e.g. floods, landslides, avalanches) and also, indirectly, meteorological events (e.g. storms and hail). Direct threats from meteorological and gravitational natural hazards will increase as a result of climate change, but also due to the steadily growing area under settlements and increasingly dense development. Heavy rainfall events and more intensive rain periods, which lead to local floods or to landslides and erosion phenomena, but also sliding snow avalanches due to temperature changes are expected to become more frequent.

Switzerland has a long tradition in the construction of hazard mitigation structures. It is therefore not surprising that Swiss avalanche protection, and thus the extensive knowledge of the use of timber for this purpose, was awarded UNESCO intangible cultural heritage status in 2018, emphasising the interplay of traditional knowledge, technology and folk culture.

The construction of hazard mitigation structures made from timber has been perfected over the centuries and utilises locally occurring tree species. In addition to the frequently used species of spruce and fir, Swiss forests also contain species such as larch and sweet chestnut, which are particularly suitable for hazard mitigation structures due to the natural durability of their wood. However, Swiss

timber is also a component of innovative products such as wood wool mats, which can be used for erosion control.

In recent decades, building materials such as steel, concrete or plastics have often been used for hazard mitigation structures in addition to timber. Due to their specific properties, there are arguments for using these materials in such structures. Depending on the application, the expected event and the desired service life, it is advisable to choose a building material that optimally meets all technical requirements. However, hazard mitigation structures made of round timber always win out in terms of sustainability, especially when local resources are used, and in combination with bioengineering construction measures.

The present Lignatec publication aims to provide a summary description of the use of timber in hazard mitigation structures against erosion and landslides, and in torrent control and avalanche protection, and to publicise tried and tested constructions and their applications. Therefore, this publication is not only aimed at experts in forestry construction technology, but also at planners in natural hazard prevention and those interested in building with wood.

Lignum would like to thank all authors and partners who contributed to this issue of Lignatec.

*Gunther Ratsch, Lignum Technology  
Editor-in-chief*

# 1 Introduction

Throughout Switzerland, gravitational natural hazards (e.g. landslides, debris flows, floods as well as rockfall and avalanches) result on average in annual damages of approx. 100 to 300 million Swiss Francs (cf. Figure 1). [1] Additional damage is caused by meteorological/climatological (e.g. hail and storms) and tectonic natural hazards (e.g. earthquakes). As

settlement areas are used more and more intensively and property values have risen, damage due to gravitational natural hazards increased considerably between 1972 and 2007. For more than two decades now, attempts are therefore under way to mitigate the effects of natural hazards by means of integrated risk management. [2]

Figure 1  
Development of annual damages due to floods, debris flows, mass slippage processes and falls between 1972 and 2018 (adjusted for inflation, base 2018). Arithmetic mean (bold, CHF 306 million) and median (dashed, CHF 96 million) calculated over the period shown are marked with horizontal lines.

■ Floods/debris flows  
■ Mass slippage processes and falls

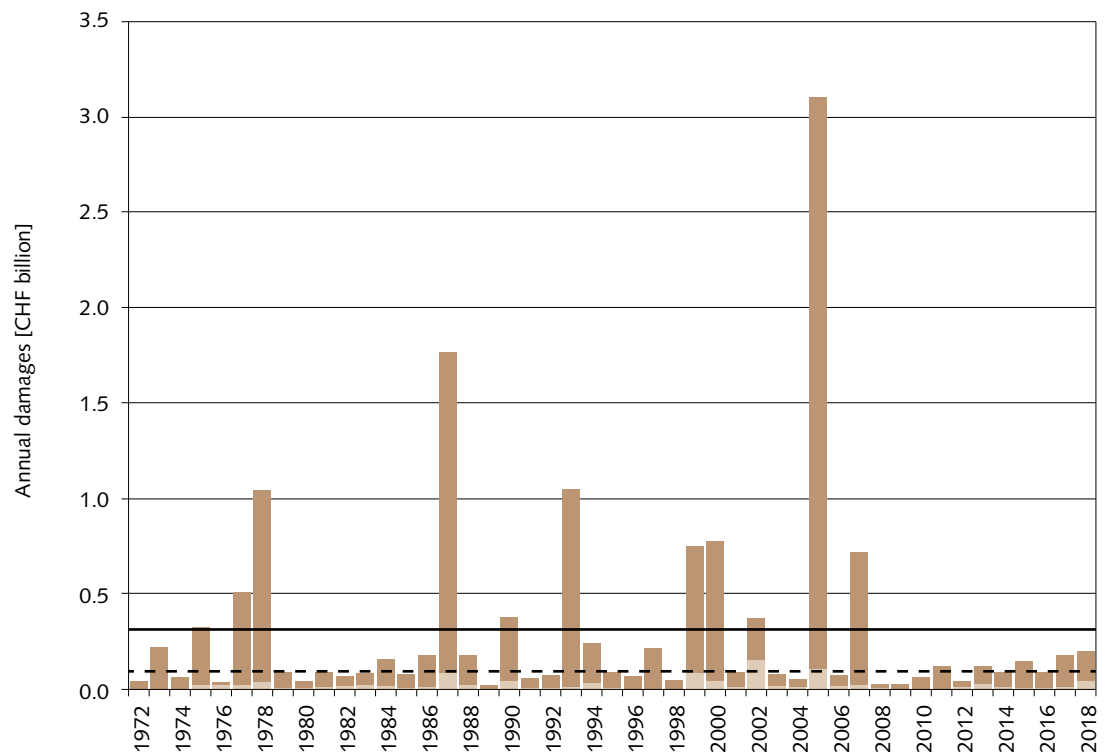

## 1.1 From hazard prevention to integrated risk management

Even though the foundations for natural hazard registers and maps have been in place for a long time [3], until well into the 1980s many assumed that gravitational natural hazards could be controlled by structural means. Although hazard mitigation structures are generally able to reduce the risk of natural hazards, it has become apparent that they usually do not offer absolute protection and in exceptional cases may even have adverse consequences. This is usually due to the fact that hazard mitigation structures cannot be dimensioned for extreme events or for interacting natural hazards. This can lead to process chaining, for example when heavy rainfall and shallow landslides carry a large quantities of sediment and wood into the channels, which can lead to blockages and unexpected flooding.

Whereas in the past a hazard event was followed by immediate damage prevention, repairs and possibly new control structures, today integrated risk management (IRM) takes a more holistic approach (cf. Figure 2). IRM takes into consideration all natural hazard processes, deals with all risks in a comparable way and includes all types of measures into action planning. At the core of IRM is the risk cycle, which includes prevention, the actual event, its management, and regeneration. Based on a hazard analysis and risk assessment, preventive measures are intended to prevent fatalities and property damage resulting from natural events. In addition, preparedness ensures that procedures are in place in the event of a crisis in which a sufficiently high level of safety cannot be achieved despite preventive measures.

Figure 2  
Simplified model  
of integrated risk  
management.

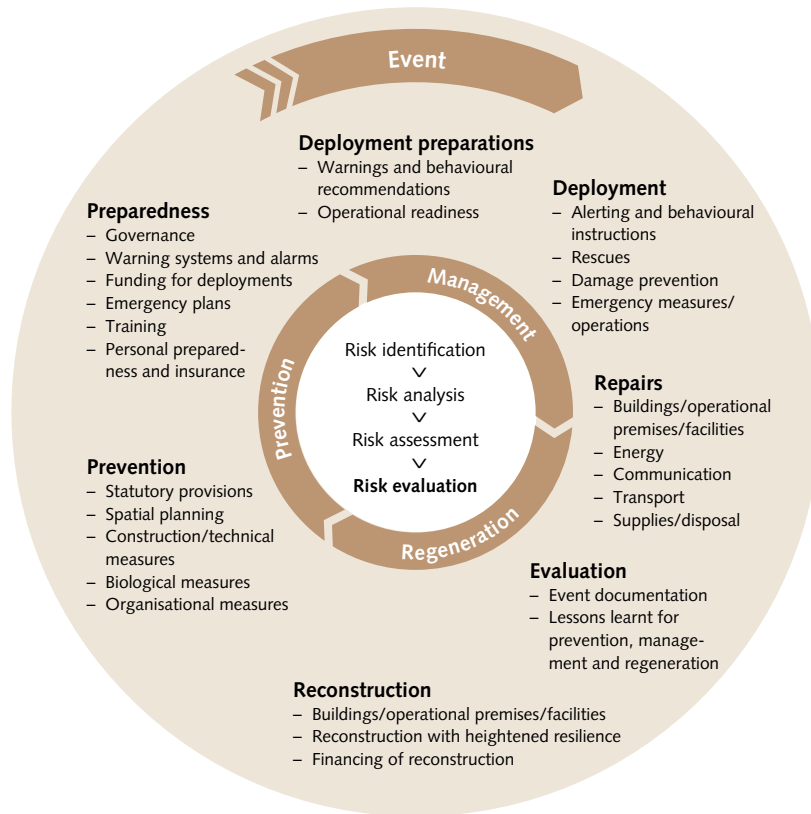

## 1.2 Measures as part of the IRM framework

The measures as part of the IRM framework can be assigned to the following areas:

- Spatial planning
- Biological measures
- Construction/technical measures
- Organisational measures

As a general principle, the first step is to use spatial planning to try to avoid hazardous areas in the landscape or not to exacerbate existing risks. In many cases, this is not possible in a country such as Switzerland. The measures that then come into effect over large areas are biological ones. These mainly concern protection forests as well bioengineering construction measures such as, for example, retaining structures made from timber in combination with reforestation.

According to the Swiss National Forest Inventory LFI [4], approximately one third or 1.32 million ha of the Swiss national territory is covered with forests, 49 % of which are protection forests. The

forest thus forms a large-scale, green infrastructure, serving an important protective function against natural hazard processes. [5] Forests can prevent the release of snow avalanches and shallow landslides, and also protect against rockfall impacts. Moreover, forests reduce bank and surface erosion in the vicinity of torrents and thus also reduce debris flows. Depending upon the spatial and temporal distribution of precipitation duration and intensity and the size of the catchment area, forests can reduce both the probability of occurrence and the intensity of flood events. In this way, forests in many places contribute to reducing natural hazard risks to a tolerable level. Thanks to their combination with protection forests, technical measures designed to meet higher protection requirements are often more cost-effective (lower installation or maintenance costs). In certain places, technical measures only make sense because of the additional protection provided by the forest. [6]

Figure 3  
Trees felled transverse to the hill slope and tall stumps in a rockfall protection forest in the canton of Jura.



As part of the management of protection forests, tree trunks felled transverse to the slope (termed *Querbäume* in German) and retained tall stumps are often used (cf. Figure 3). This is to prevent the protective effect of the forest from being reduced as a result of silvicultural interventions over a number of years. In such interventions, trees are usually felled for a variety of reasons (e.g. promotion of forest regeneration or improvement of stand structure); as a result, the number of stems per unit area (a measure of the density of a forest stand) decreases. Various scientific studies have shown that transverse, lying deadwood logs have a moderate to high protective effect (see [7] and [8] regarding rockfalls or [9] and Chapter 7 regarding avalanches). The efficacy of the protection forest, including

transverse deadwood logs and tall stumps, is mainly determined by the forested slope length and the amount of standing (basal area or number of stems and mean trunk diameter) or lying wood (see e.g. [10]).

A challenge in the management of protection forests is the service life of the transverse logs, which is determined by the wood's durability. Details are discussed in Chapter 2. Several research studies ([11] and [12]) indicate that the natural decomposition of wood, depending on species, mean annual temperature (MAT) and site humidity, leads to an exponential decrease in density and tensile strength and thus to a reduction in the protective effect. As Figure 4 shows, a beech log can lose almost 40% of its original mass just five years after felling. For a spruce log, the equivalent figure would be approximately 15%.

It is evident that forests alone are not able to reduce the natural hazard risk to an acceptable level in all locations. This is primarily due to the hazard perimeter not being sufficiently stocked (e.g. in active avalanche corridors or debris flow gullies) or because the forest's impact is locally insufficient or non-existent (e.g. in the case of flooding of areas along major rivers). In such places, the third type of measure, i.e. structural-technical measures, comes into play. Well-known examples are river dams, sediment retention basins or flexible rockfall nets. Although concrete, steel, blocks and soil are

Figure 4  
Decomposition of beech and spruce logs over time at cold sites and warmer sites, incl. scatter range, MAT = mean annual temperature (graph based on data by [11] and [12]).

- beech (MAT < 0°C)
- beech (MAT = 12°C)
- spruce (MAT < 0°C)
- spruce (MAT = 12°C)

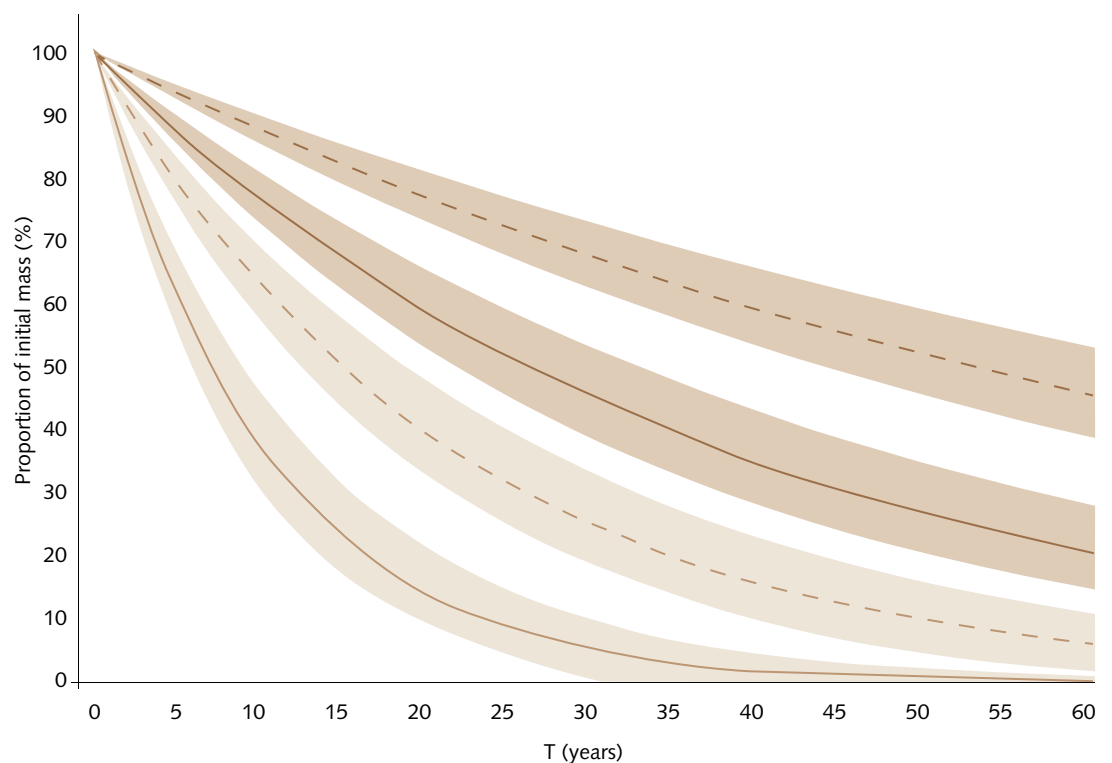

often used, wooden control structures also play an important role. Well-known examples are avalanche control structures made of wood and many other types of structures, which are explained in the following chapters. Wood is also used, for example, in palisades for rockfall protection. As part of today's risk-based management of natural hazards, the cost-effectiveness of a protective measure must be given before it is implemented. This is expressed as the ratio between the benefit of a measure (annual risk reduction) and the annual costs of the measure (total construction and maintenance costs divided by the service life of the measure). In the case of classic structural-technical measures (hazard mitigation structures built with concrete, steel, blocks or soil), cost-effectiveness is not always achieved due to the high cost of con-

struction. Measures involving wooden structures are usually associated with lower construction costs, but also with a shorter service life. The question of cost-effectiveness must therefore be examined on a case-by-case basis.

Where structural-technical measures are of insufficient cost-effectiveness, organisational measures may be able to reduce the risks. This could mean, for example, monitoring the hazard process in combination with road closures and evacuations of residential areas. Other examples would be measures designed to directly protect built infrastructure such as flood barriers made of water-filled hoses along rivers, artificial avalanche triggering or the blasting of rock packs which have been monitored by radar.

---

### 1.3 From felled logs to soil and water bioengineering

When talking about countering natural hazards with timber, one enters a variety of disciplines using different definitions and terms. It starts with the simple log felled transverse to the slope (German: Querbaum) and the discussion of whether or not it should be considered a structure. From a 2021 memorandum issued by the Legal Division of the Swiss Federal Office for the Environment FOEN regarding liability issues for transverse deadwood in protection forests, it follows that it does not in principle constitute structures within the meaning of Article 58 of the Swiss Code of Obligations, provided it is – as is often the case in practice – merely leaning against tree stumps. Only if it has a firm direct or indirect connection to the ground through active human intervention may it qualify as a structure. For reasons of proportionality and viability, simplified and attenuated monitoring intervals would appear to be both expedient and appropriate for transverse deadwood compared to classic structural-technical hazard mitigation structures. Structures built with wood, such as tripod supports, cribwalls or retaining structures, may be de-

finied as non-permanent protective measures. Such timber constructions, where wood is used as an inert material, are often combined with bioengineering construction measures. Basically, soil and water bioengineering only considers living construction materials, i.e. seeds, plants, parts of plants and plant communities. [13] Soil and water bioengineering is a component of 'ecological engineering' (internationally also called 'eco-engineering'), an approach that involves the design, construction and operation of ecosystems for specific applications. In other words, ecosystems are controlled using engineering-based methods, whereby the ecosystem consists of a community of organisms and their inanimate environment. In this sense, protective forest management, but also timber retaining structures in combination with afforestation can be considered eco-engineering. In an international context, such eco-engineering measures are now defined as ecosystem- or nature-based solutions for the reduction of natural hazard risks (see [14]). Currently, this term is increasingly gaining global attention.



## 2 Durability of wood as a building material

### 2.1 General considerations

Various environmental influences limit the use of wood in exterior construction: mechanical stresses, climatic impacts, and also living organisms such as rodents and insects, bacteria and fungi. Particularly significant for the biological degradation of wood are the wood-decomposing fungi, which are naturally responsible for wood mass loss. In order to maintain the functionality of hazard mitigation structures made of wood for as long as possible, it

is necessary to offer the wood-degrading fungi the most adverse conditions possible. It is also important to use timber species with the highest possible natural durability. Most of the following information is taken from the publication '*Holzkonstruktionen im Wildbach-, Hang- und Rensenverbau*' (Timber structures in torrent control, slope stabilisation and gully control works). [15]

### 2.2 Biodegradation of wood

Wood consists to 41–50 % of cellulose and, depending on the type of wood, 25–40 % hemicellulose and 18–32 % lignin. The microorganisms that can diffuse and break down these building blocks include bacteria and a variety of wood-decomposing fungi: moulds and blue stain fungi as well as soft-rot, brown-rot and white-rot fungi. Important prerequisites for wood decomposition are oxygen and water. A basic rule states that wood can be preserved for a long time either in a water-

saturated state or in a dried state with a wood moisture content of less than 20 % (for dry-laid wood). Another important factor influencing fungal activity, in addition to the availability of water, is temperature: the minimum temperature is at freezing point, while the optimum is between 20°C and 40°C, depending on the species of fungus; above this temperature, denaturation begins. The extent of decay also depends on exposure duration.

### 2.3 Use classes

According to SN EN 335 [16] in Switzerland, depending on the exposure to moisture and the given use situation, timber components can be divided into four use classes (*Gebrauchsklassen*, GK), and into two relevant use classes (GK3 and GK4) for hazard mitigation structures made of round timber (cf. Table 1). The classification of timber components into use classes aids the selection of a suitable

type of wood in a given situation. For example, timber components used outdoors (wood moisture content constantly above 20 %) are classified as use class 4. The recommendations made in the timber construction tables [17] for the use of certain types of wood in the given use classes are only of limited applicability to hazard mitigation structures made of round timber.

### 2.4 External and internal influences on the durability of wood

Durability refers to the natural resistance of wood against wood-destroying organisms [18], such as insects and, in particular, wood-decaying fungi. Durability is largely dependent on the presence or absence of certain heartwood forming substances. [19] Obligatory coloured heartwood, in particular, exhibits increased durability due to the secondary metabolites encrusted in the cell walls. The various tree species' sapwood differs only insignificantly in this respect and is generally less resistant (cf. Table 2). As a rule of thumb, wood can therefore be ranked in the order of decreasing fungal resistance as follows:

1. Heartwood of obligatory coloured heartwood deciduous species (there are exceptions, e.g. ash, elm)

2. Heartwood of obligatory coloured heartwood coniferous species
3. Species without obligatory coloured heartwood formation

For many hazard mitigation structures – especially when it comes to hydraulic bioengineering and slope stabilisation – the readily available species spruce and fir are often used. Since these species are not among the most durable, major consideration must be given to the structures' required service life, structural timber protection (also see [20]), the timber's condition and ongoing maintenance. Various authors consider softwood with narrow growth rings to be more durable ([21], [15]). Growth ring structure is influenced by the

Table 1  
Relevant use classes  
for constructional timber  
and potential for the  
occurrence of harmful  
organisms pursuant to  
SN EN 335 [16] and [17]  
for Switzerland.

Use class	General service conditions		Moisture content of wood <sup>2)</sup>	Potential occurrence of harmful organisms <sup>3)</sup>
1 <sup>1)</sup>	Indoors, dry		dry, constantly under 20 %	rarely wood-destroying insects
2 <sup>1)</sup>	Indoors <sup>4)</sup> or under roof, not exposed to the weather, potential condensation		occasionally above 20 %	same as use class 1 wood-staining fungi
3.1	Outdoors, without soil contact, exposed to the weather	limited humid conditions <sup>5)</sup>	occasionally to frequently above 20 %	same as use class 2 wood-destroying fungi (brown-rot, white-rot)
3.2		persistent humid conditions <sup>6)</sup>	frequently to predominantly above 20 %	same as use class 2 wood-destroying fungi (brown-rot, white-rot)
4	Outdoors, in contact with soil or water		constantly above 20 %	same as use class 3 wood-destroying fungi (soft-rot), bacteria

<sup>1)</sup> Use classes 1 and 2 have no significance for the application of hazard mitigation structures.

<sup>2)</sup> The terms 'occasionally', 'frequently', 'predominantly' and 'constantly' indicate increasing stress, but because of the very different influencing variables these terms are not precisely quantified.

<sup>3)</sup> Protection against all listed organisms is not necessarily required, as they do not occur under all conditions of use in all geographical locations, are not economically significant, or are not capable of infesting certain wood products due to the products' specific condition.

<sup>4)</sup> If conditions with regular heavy humidification are to be expected in indoor applications, e.g. in wet areas and in non-ventilated cellars (due to spraying water or heavy condensation), the application should be assigned to the corresponding use class 3.1 or 3.2.

<sup>5)</sup> Where water cannot pool and the wood or wood product does not stay wet for prolonged periods.

<sup>6)</sup> Components where deposits of dirt, soil, leaves, etc. must be expected to occur for several months, and components subject to particular stresses, are to be classified as use class 4.

growth conditions to which a tree is exposed. These include the site, the tree's sociological position in the stand, its age, and silvicultural measures. With regard to the site, availability of water and nutrients are crucial, while altitude, exposure and the length of the growing season also play important roles. In simple terms, the harsher the living conditions for the tree, the slower it develops and the narrower the growth rings will be. Narrow-ringed wood can therefore be expected to be found, for example, at higher altitudes, but also from suppressed to co-dominant trees as well as on sites with moderate to poor growing conditions. In addition to the selection of a suitable wood species, the best possible building material for hazard mitigation structures made of wood could therefore theoretically also be provided by the targeted se-

lection of trees during felling. However, Nötzli [22] points out that the question of the durability of timber used in construction with reference to its growth ring structure must be considered in a more nuanced way and that further research is needed on this issue.

The question often arises as to whether wood should be debarked prior to being used in protective measures. Debarked wood is usually used for protection from avalanches and snow slides. For flood protection, both barked and debarked wood can be used. However, according to a long-term study of wooden crib dams made from spruce or fir, debarked wood tends to be less durable. [27] Especially mechanical debarking is suspected to be unfavourable as it damages the xylem.

Table 2  
Natural durability of indigenous timbers according to SN EN 350 [23] and classification of their service life according to [19].

Service life <sup>1)</sup>	Trade name	Code pursuant to EN13556	Scientific name	Fungi <sup>2)</sup>	Anobiid <sup>3)</sup> (beetles)
15–25 years	Robinia	ROPS	Robinia pseudoacacia	DC 1–2	DC D
	Sweet chestnut	CTST	Castanea sativa	DC 2	DC D
	Yew	TXBC	Taxus baccata	DC 2	DC D
	Oak	QCXE	Quercus robur	DC 2–4	DC D
10–15 years	European Larch	LADC	Larix decidua	DC 3–4	DC D
	Douglas fir	PSMN	Pseudotsuga menziesii	DC 3–4	DC D
	Scots pine	PNSY	Pinus sylvestris	DC 3–4	DC D
5–10 years	Norway spruce	PCAB	Picea abies	DC 4	DC S
	European silver fir	ABAL	Abies alba	DC 4	DC S
	Wych elm	ULGL	Ulmus glabra	DC 4	DC S
	Ash	FXEX	Fraxinus excelsior	DC 5	DC S
	Poplar	PONG	Populus alba	DC 5	DC S
< 5 years	Sapwood			DC 5	DC S
	Grey alder	ALIN	Alnus incana	DC 5	DC D
	European beech	FASY	Fagus sylvatica	DC 5	DC S
	Hornbeam	CPBT	Carpinus betulus	DC 5	–
	Birch	BTXX	Betula pendula	DC 5	DC D
	Sycamore	ACPS	Acer pseudoplatanus	DC 5	DC D
	Willow	SAXX	Salix spp.	DC 5	–

<sup>1)</sup> Durability of some native wood species, divided into classes of approximate service life of 5 × 5 cm wooden stakes in contact with the ground (according to Findlay 1962 [24], in Bosshard 1984 [19])

<sup>2)</sup> natural durability against fungi: DC 1 = very durable to DC 5 = non-durable pursuant to SN EN 350

<sup>3)</sup> natural durability against insects: DC D = durable, DC S = non-durable pursuant to SN EN 350

Figure 5 (left)

If sweet chestnut roundwood is to be used, availability needs to be checked (cross-sections, lengths).



Figure 6 (right)

Avalanche control structure made of sweet chestnut.



---

## 2.5 Durable timber species and their occurrence in the Swiss forest

As can be seen in Table 2, there are four native timber species that are assigned to durability class 2 (durable): robinia, sweet chestnut, yew and oak. It should be noted that the share of robinia in the Swiss forest is only approx. 0.1 % (Swiss National Forest Inventory [4]). The shares of oak and sweet chestnut in the total tree population in Switzerland are 2 % and 1 % respectively. Looking at the regional distribution, the share of sweet chestnut on

the southern side of the Alps is 15 % and the share of oak in the Central Plateau is 5 %. [25] Species such as larch with a share of 5.5 %, Douglas fir (0.3 %) and pine (2.7 %) can also be counted among the more durable timber species. [4] With a view to sustainability (cf. Chapter 8), the use of regionally sourced wood is advised, in so far as possible, so that transportation distances can be minimised.

---

## 2.6 Criteria for the use of wood for hazard mitigation structures

Wood degradation or the reduction of timber strength due to wood-decomposing fungi can be limited either by wet storage (oxygen deprivation) or drying (water deprivation). Durability can also be increased by means of wood preservation treatments, although for ecological reasons such wood is hardly ever used for hazard mitigation structures nowadays. Wood degradation progresses particularly rapidly under alternating humidity conditions, for example at the air/soil interface.

Hazard mitigation structures made of wood are used in a variety of situations:

- for slope stabilisation and slide restoration (see Chapters 4 and 5)
- for drainage and flood protection in torrent catchment areas (see Chapter 6)
- for protection against avalanches and snow slides (see Chapter 7)

Depending on the structures' intended use, the work sites' environmental conditions vary greatly. In the case of structures designed to protect against snow slides and avalanches, the aim is to achieve the driest possible conditions in order to ensure a long service life. In contrast, for the above-mentioned reasons, efforts in hydraulic engineering must be directed towards permanently high wood moisture contents. Structural elements in alternating humidity conditions are particularly at risk and must be protected accordingly. In avalanche and sliding snow protection measures, such conditions

are prevalent at all interface areas, e.g. between supports and the ground. In the case of stream barriers or check dams, it is the wing walls and lateral anchorings that are not in constant contact with water. Similarly, a longer service life can be expected for timber in permanently waterlogged gley soils than in soils of alternating humidity such as pseudogleys. In the case of wooden torrent control structures, altitude and aspect have been found to be important factors in addition to water saturation: At structures at lower altitudes and areas with a southern aspect, loss of strength progressed more rapidly ([15], [26]). To regulate climatic conditions and protect against temporary desiccation, it is advisable to shade the structures by planting riparian vegetation. In slope stabilisation, structures should be covered as completely as possible with soil and vegetated. For structures where such cover is not an option, a reduced service life must be expected.

Under favourable conditions, protective structures made of wood can fulfil their function for a very long time. For example, in Plaffeien (Friburg) and Gams (St. Gall) stream barriers were found to be in satisfactory overall condition after up to 75 years and 100 years respectively. [15], [26] However, the most critical factors for a long service life are not only timber of the highest possible durability, but also a suitable structural concept, design and quality of workmanship, mechanical loads that are not overly extreme and, in particular, the permanent maintenance and monitoring of structures.

## 2.7 Case study of a series of check dams in a torrent

Some of the above-mentioned aspects will be illustrated here, using the example of an investigation conducted by the Swiss Federal Institute for Forest, Snow and Landscape Research (WSL) on wooden torrent barriers: In Hergiswil (Nidwald), a step-wise correction works consisting of 15 double-walled wooden crib dams was constructed in 1996. Since then, the condition of the works has been regularly documented. [27] Three years after completion, the first fruiting bodies of fungal tree pathogens were observed on the barriers. In the following years, further fungi occurred, especially where the upper longitudinal wood is anchored into the stream bank. Over time, a total of 18 different species of fungi were recorded.

Timber strength was regularly assessed using a qualitative method. The test parameter was the penetration depth of a screwdriver. The first areas of incipient wood decay were discovered five years after construction. After ten years, rot was noted in about half of the barriers, and at the final survey in November 2020, i.e. 24 years after construction, all barriers were showing some local areas of rot. In the areas of alternating humidity at the structures' edges, timber strength was reduced much more frequently than in the constantly wet drainage areas. In general, areas of rot occurred mainly in the upper area (cf. Figure 7). In contrast, the permanently water-saturated base of the barrier remained practically free of decay. If restoration measures were undertaken, the lower layers could therefore be left as a foundation and the more degraded upper layers replaced. Overall, it should be noted that after 24 years, despite the signs of local decay, all the structures were still fully functional. Only in one of the structures slight sagging of the wing walls was observed.

Figure 7  
24-year-old wooden torrent dam (Hergiswil, Nidwald) with incipient wood decay in the area of alternating humidity on the right below the silted up section and the wing wall.



### 3 Standards and notes on the dimensioning of hazard mitigation structures made of round timber

---

#### 3.1 General considerations

---

In practice, the timber structures dealt with here are usually erected on the basis of standard designs with structural specifications for the dimensions of the structural components (see Chapters 4, 5, 6 and 7).

For structures that are pushing the envelope of standard design or are erected in geotechnically sensitive areas, the load-bearing capacity should be separately verified. Similarly, when developing new or optimising existing standard designs, it may be necessary to statically dimension the structure's components. Hazard mitigation structures made of round timber (barriers, retaining walls, slope stabilisation) are considered structures in soil contact. Therefore, a check of the overall stability, the subgrade and the structural components must be taken into account in the design. In forestry construction technology, the concepts of external and internal load-bearing safety have become established in accordance with standard SIA 267. [28] According to standard SIA 260 'Basis of Structural Design' [29], four limit states are to be considered for verifications of load-bearing safety:

- Type 1 concerns the overall stability (external load-bearing safety). With regard to overall stability or external load-bearing safety, failure

states in the surrounding subgrade are considered. This includes verifications regarding tilting and sliding.

- Type 2 concerns the load-bearing resistance of the structure or one of its parts (internal load-bearing safety). Internal load-bearing safety considers failure states in the timber structure. This includes failure due to fracturing, excessive deformation, transformation of the structure into a mechanism or loss of stability (e.g. verifications regarding bending and shear stress or stability of compression piles). In addition, the connections and fastenings are to be dimensioned.
- Type 3 concerns the load-bearing resistance of the subgrade (landslide, slope failure, terrain failure). For structures on slopes, for example, the soil shear strength, i.e. resistance to deformation from horizontal and vertical impacts, must be verified.
- Type 4 concerns the fatigue strength of the structure or one of its parts and describes the load-bearing resistance with regard to frequently repeated impacts. It has no significance for the verification of hazard mitigation structures made of round timber.

#### 3.2 Standardisation

---

Standard SIA 260 [29] sets out the aspects of execution, use and maintenance of load-bearing structures. As hazard mitigation structures made of round timber are structures with certain special features, structural standards are to be applied *mutatis mutandis* (cf. standard SIA 260 (0.1.3) and (0.1.4)). [29] The service life of hazard mitigation structures made of round timber is to be deter-

mined on a project-specific basis. The limit states of serviceability are not addressed, as these are only of secondary importance for hazard mitigation structures made of round timber. The following sections outline the relevant standards for the determination of stresses and dimensioning for Switzerland. Where Swiss standards are absent, reference is made to standards from abroad.

---

### 3.3 Standards for the determination of stresses

For the design of hazard mitigation structures made of round timber, the permanent and variable stresses are to be determined, taking into account the limit states and corresponding load coefficients (cf. Standard SIA 260 Table 1 [29]). No consideration needs to be given to earthquakes as exceptional impacts in the design of round timber hazard mitigation structures of building classes I and II (e.g. retaining structures or embankments in the vicinity of transport routes of considerable importance), taking into account the restrictions pursuant to standard SIA 267 Clause 7.2.3. [28]

#### 3.3.1 Retaining structures and slope stabilisations

For retaining structures and slope stabilisation, the stresses exerted by earth pressures and surface loads can be found in the SIA 261 standard 'Actions on Structures'. [30] According to standard SIA 261/1 'Actions on Structures – Supplementary Specifications' [31], stresses due to gravitational natural hazards are to be determined using the applicable recommendations and guidelines of the federal government and by means of hazard and intensity maps. If no information is available, the stresses must be determined with the help of an expert (cf. standard SIA 261/1 (2)). Further information can be found in [15] and [32].

---

### 3.4 Standards for the verification of type 1 and type 3 limit states

The basic principles for the geotechnical design of retaining structures and slope stabilisation (structural and design models) are given in standard SIA 267 'Geotechnical Design'. [28] Information on the design of the foundations of avalanche control structures (anchors, micropiles, ground plates) can be found in the technical guideline '*Lawinverbau im Anbruchgebiet*' (Avalanche control in the release area) [34] and in ONR 24806 '*Permanenter technischer Lawinenschutz – Bemessung und kon-*

#### 3.3.2 Check dams

There are no detailed standards for the dimensioning of check dams in Switzerland. The verification of load-bearing safety follows the customary design procedure for retaining structures pursuant to SIA 267. [28] Information on design and construction can be found in the German-language documents '*Holzkonstruktion im Wildbach – Hang- und Rensenverbau*' (Timber construction in torrents – slope and gully control works) [15] and '*Wildbach- und Hangverbau*' (Torrent and slope stabilisation). [32]

The Austrian standards contain action models for stresses exerted by torrents. For example, the technical rule ONR 24801 [33] contains information on static and dynamic actions on structures.

#### 3.3.3 Avalanche controls

For the dimensioning of avalanche control structures, action models for static snow pressure due to the gliding and creeping snowpack can be found in the German-language technical guideline '*Lawinverbau im Anbruchgebiet*' (Avalanche control in the release area). [34] The action models were primarily developed for the design of retaining works. For the design of protection measures against gliding snow, the calculations must be adapted accordingly, whereby the influence of edge effects in particular must be taken into account. ONR 24805 [35] incorporated the models contained therein.

*struktive Ausgestaltung*' (Permanent technical avalanche control – design and construction). [36] The foundations of avalanche control structures made of wood are usually based on experience without verification of statics pursuant to the '*Bauanleitung Gleitschneeschutz und temporärer Stützverbau*' (Construction manual for gliding snow protection and temporary supporting structures). [37]

### 3.5 Standards for the verification of type 2 limit state

Internal load-bearing safety can be verified using standards SIA 265 'Timber Structures' [38] and SIA 265/1 'Timber Structures – Supplementary Specifications'. [39]

For the dimensioning of hazard mitigation structures made of round timber, a classification of the available building material into strength classes is the basic prerequisite for a correct verification of the components' load-bearing safety. Criteria for the visual grading of round timber and the resulting classification into one of the three strength classes can be found in the standard SIA 265/1 Table 5. [39] Two strength classes (C16 and C24) are given for coniferous wood and one strength class (D30) for deciduous wood. When selecting roundwood, special attention should be paid to reaction wood, cross-grained wood, deformations and knots, which reduce the load-bearing safety. Mechanical damage, which can occur during felling, transport or processing, impacts strength and is also a prime entry point of fungal infections.

Characteristic properties and dimensioning values for visually graded round timber can be found, by analogy, in Table 8 of standard SIA 265. [38] The properties and design values shown there refer to an average wood moisture content of 12 %. Since the wood moisture content greatly influences the strength properties, the dimensioning values are to be mitigated for higher wood moisture contents by multiplying with a coefficient. For exceptional design situations, the dimensioning values for timber components pursuant to standard SIA 265 (2.2.6) [38] may be increased by applying the coefficient that accounts for stress duration.

Due to the timber's natural degradation, the statically effective cross-section changes over time. As these degradation processes are strongly dependent on the timber species, the use and the surrounding macro- and microclimate, it is difficult to estimate the effective cross-section to be used in

calculations. A stronger dimensioning up to what may appear to be oversizing can buffer against uncertainties. However, overly large cross-sectional dimensions may also result in delayed drying. It is helpful to draw on experiences from structural projects erected under similar environmental conditions. Depending on the application, the basic rules of structural timber protection should be taken into account, such as protecting end-grain cuts and avoiding standing water on structural components. Information on determining geometric parameters of round timber (cross-section area, moment of resistance, moment of inertia, radius of inertia) as well as the buckling resistance for coniferous wood of strength class C16/C24 can be found in the timber construction tables. [17]

The technical guideline '*Lawinenverbau im Anbruchgebiet*' (Avalanche control in the release area) [34] provides information on the design and dimensioning of avalanche control structures made of wood. The Austrian technical standard ONR 24802 [40] can be useful for the planning, design and construction of torrent controls. This standard contains general specifications for the construction of check dams, but no specific details on timber structures. Information on the design of timber structures in torrent, slope and gully control works can also be found in the German-language '*Holzkonstruktionen im Wildbach-, Hang- und Runsenverbau*' (Timber structures in torrent control, slope stabilisation and gully control works). [15]

#### 3.5.1 Dimensioning of fasteners

For the dimensioning of dowel-type fasteners (nails, screws, bolts), the specifications of standard SIA 265 [38] are to be applied. The verification of steel components is to be conducted pursuant to standard SIA 263. [41]



## 4 Timber for erosion control

---

### 4.1 Processes and impacts

---

Erosion is a process in which the removal of soil or weathered material occurs due to external forces. These are the effects of the movement of water, solids, air or a combination of these at the contact interface. This chapter specifically addresses soil erosion caused by falling or flowing water. Five different types of soil erosion can be defined in this regard.

#### Splash erosion

This is the initial stage of soil erosion, which is caused by the force of raindrops hitting the soil aggregates (splash effect). [42] The energy of the raindrops can be much higher than that of surface water runoff and can thus detach soil particles (mineral or organic material) from aggregates which otherwise could not be eroded by water runoff. [43]

#### Interrill erosion

This term describes the mobilisation and transport of soil particles by surface runoff of water on a small spatial scale. Because runoff energy is limited, this process primarily transports material that has already been mobilised by splash erosion and remains in suspension in the water (fine organic matter, clay and silt fractions). Once they have accumulated, the sand and gravel fractions can also be displaced in the form of debris-flow-like processes (soil slumps), depending on the slope.

#### Rill erosion

This process is characterised by a continuous action of concentrated flowing water over a lengthier period of time (for example during a precipitation event). This process can be a combination of continuous sediment transport and irregular, debris-flow-like processes.

#### Gully erosion

If the depth of erosion is greater than 0.3 m, a gully is formed, in which the erosive impacts are stronger than in rills due to the higher specific discharge, but are caused by the same processes.

#### Pipe erosion

Where runoff flow is predominantly subsurface, hydraulic erosion can lead to the formation of larger 'soil pipes'. These can collapse and thereby tear up the soil surface. [44]

The impact of measures on a specific process can be differentiated as a function of the spatial impact. [45] A distinction is made between an effect in the 'contributing zone' (for example, the reduction of water runoff from the contributing area of the catchment), in the 'process zone' (for example, the reduction of the water's tractive stress as a result of the flattening of the terrain in the area where erosion takes place), and in the 'runoff/runout zone' (for example, the construction of a sediment retention basin in the lower transit or deposition area).

### 4.2 Overview and function of erosion control structures

---

In the 'process zone' (process source), the application of structures to control surface erosion processes can be categorised into four types [45]:

- Physical shielding of soil particles: Covering the soil with robust material and/or dense plant cover can reduce the kinetic energy of raindrops and thus eliminate the effects of splash erosion.
- Increase in roughness: This reduces the runoff velocity and increases infiltration.
- Flattening of the terrain: By constructing timber sills or terraces (berms), the slope can be locally reduced, thereby reducing the shear stress of flowing water and the driving component of the soil particles' weight force. The functionality of these measures corresponds in part to that of check dams (see Chapter 6).
- Drainage of surface water: The targeted accumulation and drainage of water reduces infiltration into deeper strata or natural runoff into critical areas. As measures of this type can promote the formation of concentrated runoff and thus the development of rill and gully erosion, appropriate bed protection may be needed, depending on the situation.

### 4.3 Construction and application of erosion control structures made of wood

#### 4.3.1 Slope erosion control matting made from wood wool

Slope erosion control matting reduces erosion by raindrops, surface erosion and the formation of rill erosion. According to the Swiss wood wool standard, wood wool consists of wood fibres that are 0.1–0.25 mm in thickness and 1.3–8 mm in width. The wood wool threads are up to 500 mm long and are felt-quilted together with a biodegradable polypropylene grid or netting made of natural fibres. The production in Switzerland of nets made of domestically produced natural fibres (cellulose) is at a testing stage. Various types of wood wool erosion control matting are available, with the individual mix of fibres from different tree species playing an important role for the wood wool's durability, strength and stability (e.g. beech is less durable than fir or spruce). Timber species such as robinia, chestnut and larch have also already been tested and used. There are no design criteria for the installation of erosion control fabrics; rather the manufacturer's installation instructions are to be

followed. It is important that the fabric is laid overlapping and free of tension. The tension generated by its own weight between the fixing points must not be higher than the fabric's tensile strength. [46] During installation, it is important to ensure that no voids are created between the fabric and the ground (cf. Figure 8). To this end, stakes can be used to affix the fabric to the slope (cuttings of willow species are best suited), 3–5 cm in diameter and 30–50 cm in length. Depending on the situation, appropriate seed is used before or after fabric installation to establish a vegetation cover. The mats must function perfectly until the vegetation can assume their function (approximately 6–24 months, 2–3 vegetation periods depending on the location). Due to the fabric's excellent water retention capacity, good surface drainage and the niches between the fibres, wood wool erosion control mats improve the microclimate (moisture, temperature) for rapid vegetation establishment and reduce the risk of undercutting.

Figure 8  
Erosion protection with slope erosion control matting made of wood wool.



The general advantages of slope erosion control matting are the immediately effective protection of the soil surface, easy handling and the fact that the mats are completely biodegradable. Moreover, wood wool erosion control mats are made from local wood – certified with the 'Swiss Wood' label.

They are a sustainable alternative to imported natural fibre variants such as coconut and jute and prevent introductions of unwanted exotic organisms. As a result, the product offers strong life cycle benefits.

### 4.3.2 Terraces (berms)

Terraces are constructed in order to reduce slope inclination over large areas and to focus steep sections into small areas. This flattening reduces the tractive stress of flowing water and thus reduces surface erosion. In terms of dimensioning, the same principle applies as for check dams, with the critical slope serving as the criterion for reducing erosion rates. These measures are not intended to stabilise shallow landslides, but they have the advantage of increasing soil moisture and thus promoting vegetation establishment on dry sites.

Terraces can be built using a variety of timber constructions (cf. Figure 9 and Figure 10), mostly with fixed and anchored wooden logs (appr. 30 cm in diameter; pile walls), boards (appr. 30 cm wide and 2.5 cm thick) or single-walled wooden cribs (see Chapter 5.3.3). Terraces with cribwalls span several meters in length, with heights up to 2 m. Higher single-walled wooden cribs tend to become unsta-

ble over time and cannot be held up by vegetation. Wooden logs are up to a maximum of 50 cm high, 2–3 m long and are staggered along the slope. Where possible, these structures should be combined with vegetation and longer-lived woody plants, the roots of which ideally assume the protective function after the structures have decayed. The posts (cf. Figure 11) can be made from logs approximately 1.3 m in length, or alternatively from willow cuttings. They should be placed at the outer quarter of the length of the log or boards to reduce deformation or material failure (bending stress). The number of terraces required depends on the site's soil and the original slope inclination. These measures are most effective on slopes of 30° to 40°. In the same manner as for stream control, construction progresses from bottom to top of the slope.

Figure 9 (left)  
Terrace made of now decomposed single-walled wooden cribs combined with a water drainage channel in Arieschbach, Grisons, Switzerland.

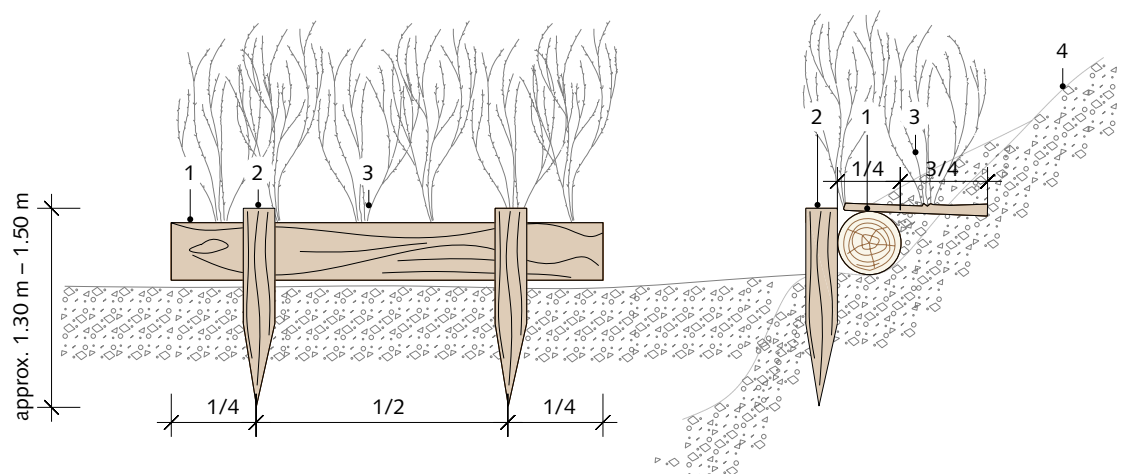

Figure 10 (right)  
Vegetated terraces made of wooden logs.



Figure 11  
Recommendations for the construction of wooden logs.

- 1 Wooden log (d = 300 mm, length 2–3 m)
- 2 Post, d = 200 mm
- 3 Willow cuttings
- 4 Slope inclination 30° to 40°



#### 4.3.3 Open channel (water drainage channel)

Water drainage measures ensure the targeted and rapid drainage of rainwater and melt water and also of captured spring water or groundwater and protect against bed and lateral erosion (gully erosion). Moreover, drainage increases soil strength (higher apparent cohesion and lower pore water pressure). The design of the open channel may vary (see [47]) and should have low roughness and a small circumference to cross-section ratio for hydraulic efficiency. V-shaped (cf. Figure 12) and rectangular channels (cf. Figure 13) are the most common.

The discharge cross-section is dimensioned pursuant to Strickler's approach for a one-in-100-years precipitation event. [47] It must be taken into account that turbulent conditions often occur and therefore an additional safety margin must be calculated into the design. In addition, there is also the effect of air mixed in the water, which increases the runoff volume. For smaller discharge depths (less than 1 m), a safety margin of 1.5 can be used to take these effects into account. In addition, a safety margin of 2 should be applied to the dis-

charge capacity so that the effects of clogging or sediments do not unduly restrict the drainage function.

The curvature of the drainage direction should also be taken into account in dimensioning so as to avoid lateral leaks. Baffle boards should be installed in problematic sections where water could overflow. Where there are convex breaks in slope, drops of more than 5 % should be avoided to ensure that no excessive waves are created. Overlaps at the individual channel segments (butt joint) should be freely movable and sufficiently long (appr. 25 cm) to prevent backflow (seepage) of water. [47]

The great advantages of such timber constructions are their adaptation to slope deformations and the use of local materials. However, they are also susceptible to damage from snow pressure or rock-fall. Therefore, they need regular checks and maintenance. Without maintenance, open gutters can even be counterproductive, as they concentrate runoff. A defective open channel promotes water seepage into the landslide body as well as gully erosion.

Figure 12 (left and centre)  
Examples of the construction of a V-channel.

Figure 13 (right)  
Rectangular duct made  
of wooden beams.



#### 4.3.4 Deadwood fascines

Deadwood fascines (made of trunks, branches, or sawmill residues and slab wood) are used for drainage and subsurface drainage of slope water from clayey and silty soils (cf. Figure 14 and Figure 15). The preferential flow paths along the branches and trunks greatly increase the soils' average permeability in the line of slope and thus reduce water infiltration. At the same time, the embedded wood prevents the development of subsurface erosion, which could otherwise occur in open ditches.

The planned drainage is staked out in adaptation to the terrain. The trench dimensions depend on the runoff; they are usually 0.5–2 m deep. Once the trenches have been excavated, the fascines are inserted. It is important to ensure that the fascines have a large contact area with the trench bottom so that they can fulfil their function with no bed erosion occurring. To this end, the fascine should

be well compacted and possibly covered with a layer of the excavated material. The lowest part of the fascine at the base of the slope should be left as free of obstructions as possible (no filtering effect) so that no blockage can occur. Water can be collected at the base of the slope in controlled collection pits or open trenches. Silt collectors need to be constructed where sediments can settle before the water moves on.

Local and biodegradable materials can be used, resulting in a sustainable construction. The disadvantage mainly lies in the difficulty of monitoring for functionality (e.g. whether pipe erosion occurs). On slopes where severe deformation occurs, the effect of these measures can quickly diminish. In combination with bioengineering construction measures (cuttings or live fascines), this measure can be effective and logistically simple.

Figure 14 (left)  
Drainage construction  
using deadwood fascines.



Figure 15 (right)  
Completed drainage  
with deadwood fascines.



## 5 Timber for landslide control

### 5.1 Processes and impacts

Landslides are gravitational processes that mobilise entire packs of soil material or regolith. For a simpler classification, one can distinguish between shallow landslides (with failure depths < 2 m), medium landslides (with failure depths > 2 m and < 10 m) and deep landslides (with failure depths > 10 m). Shallow landslides normally occur as spontaneous translational movements (shear surface is parallel to the slope) and can run out as debris flows (channelised or non-channelised) or

mudflow where there is strong liquefaction of fine material (cf. Figure 16 A). Slope instabilities caused by a change in terrain geometry and load conditions (e.g. during road construction) (cf. Figure 16 C) can occur as translational or rotational movements, depending on the soil material. Deep landslides mostly occur as rotational movements (cf. Figure 16 B) or complex landslide bodies with differential movements (cf. Figure 16 D).

Figure 16  
Conceptual representation of possible slide mechanisms.

- A** Translational slide with linear rupture surface
- B** Rotational slide with circular rupture surface
- C** Translational landslide after terrain change (active pressure wedge)
- D** Complex slide with differential movements

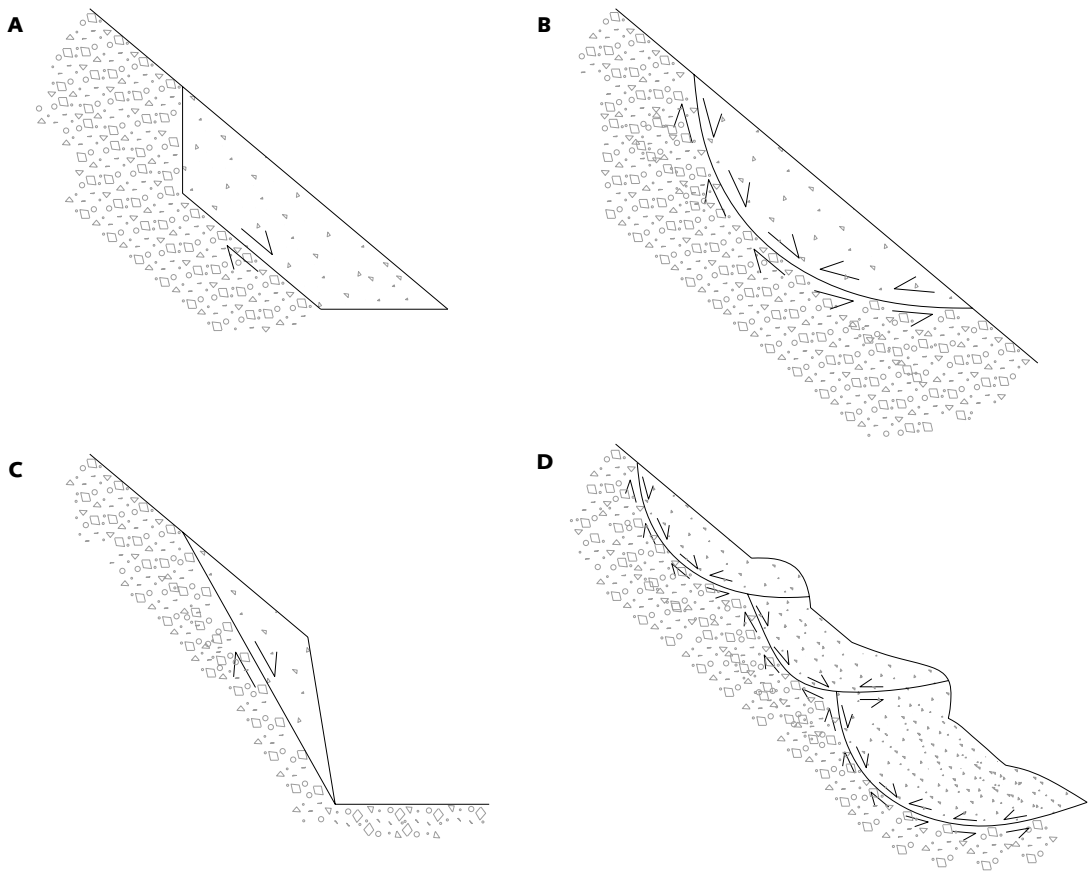

The analysis of the factors that lead to slide processes is important for defining correct measures. A distinction is made between predisposition, variable disposition and triggers. The predisposition includes aspects such as slope, geology and exposure, which do not change much over time. The variable disposition includes, for example, the condition of the vegetation (or root reinforcement)

and the soil properties (e.g. moisture, distribution of silt/clay fraction, soil depth), which can change in the medium term. The triggers are short-term events; in most cases the trigger is an increase in pore water pressure due to heavy precipitation or concentrated water runoff (e.g. from road drainage or defects in water pipes).

For an improved classification of the effects of protective measures it is important to analyse the phases of activation of the resistance forces in the structures during a landslide's development (cf. Figure 17). In the first phase, the soil's shear resistance is mainly activated along the locally along the shear surface (point 1 in Figure 17). In the second phase, additional lateral tensile resistances are mobilised in the upper failure zone of the landslide (point 2 in Figure 17). In the third phase, as

soon as most of the lateral tensile resistance has been lost, it is mainly compressive forces that act in the lower failure zone (point 4 in Figure 17). During this phase, the stiffening of the landslide body, e.g. by means of slope grating, can play an important role (point 3 in Figure 17). Moreover, other structural elements such as timber cribs or wooden logs react to this load with compressive resistance (passive earth pressure force).

Figure 17  
Schematic representation of the mobilised resistive stresses during the development of a shallow landslide.

- 1 Shear stress
- 2 Tensile stress at the upper part of the failure edge
- 3 Compressive stress in the line of slope
- 4 Compressive stress at the lower part of the failure edge
- 5 Lateral root reinforcement under tension
- 6 Basal root reinforcement
- 7 Stiffening of the landslide body
- 8 Lateral root reinforcement under pressure

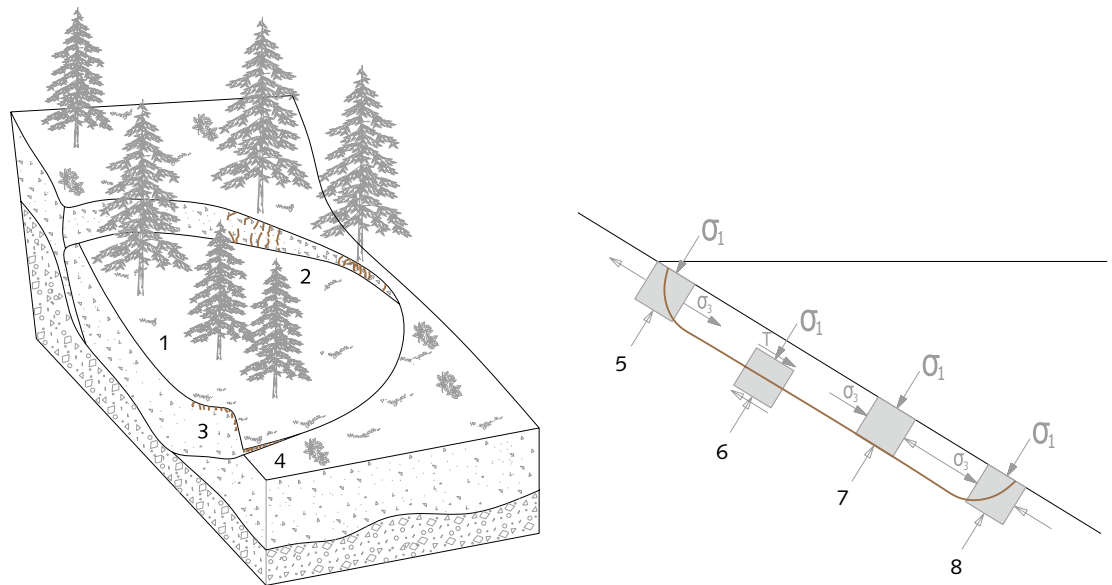

## 5.2 Overview and function of landslide control structures

Generally there are three types of structures for the stabilisation of slopes at risk of landslides:

### Supporting structures

This refers to structures that support and partially stiffen potential sliding masses. Sliding slopes are stabilised by means of force transmission (pressure or shear or a combination of these mechanisms). It is important to characterise the slide processes' mechanisms as well as possible in order to determine the correct structure and its functionality. For example, in shallow translational landslides with lengths < 20 m and a stable slope foot, slope grates

stiffen the displaced mass, and the greater part of the destabilising forces is distributed under pressure at the slope foot. Where the length of the shallow translational landslide is too great and it is possible to build into stable subsoil (into the landslide body or on its side), timber cribs can be used to dissipate the compressive forces into stable areas.

### Retaining structures

Works of this type need anchors to transfer the stabilising resistance forces from deeper stable areas into the landslide body that is to be stabilised.

### Drainage measures

These measures have a stabilising effect by reducing the pore water pressure in the landslide body and possibly by maintaining the apparent cohesion (in the unsaturated state).

All the above-mentioned types of structures are to be considered temporary structures of severely lim-

ited durability, which are always to be implemented in combination with soil bioengineering measures. The assumption must always be that in such a context the structure will be destroyed in the short or medium term. Whenever possible, the use of artificial building materials (PVC, sheet metal, concrete, iron, etc.) should be avoided for the same reason.

## 5.3 Construction and application of wooden stabilising structures

### 5.3.1 Anchored logs

Anchored wooden logs can be used to provide selective support to shallow landslides. The pressure forces of the potential landslide body (driving forces minus shear resistance of the landslide surface and of the earth wedge between the log and the front of the displaced mass) act on the logs and are transmitted through the anchoring into the subsoil. The maximum resistance, which has a stabilising effect parallel to the slope, corresponds to the passive earth pressure force. [48] The foundations (anchors or dowels) transfer parts of the resistance forces under tension or shearing/bending into the stable subsoil. The maximum passive earth pressure force can serve as a criterion for the dimensioning of the distances between the logs. The lateral pressure forces of the unstable soil layers (which are proportional to the distance between the logs) should not be greater than the component of the passive earth pressure force in the line of slope (cf. Figure 18).

If the soil between the logs is not stiffened by means of bioengineering revegetation measures, cracks are to be expected due to soil settlement. This in turn could promote infiltration of surface runoff and cause an increase in pore water pressure (or a decrease in apparent cohesion) in the landslide body, thus reducing the effect of the measures.

Simple round logs with a length of 3–5 m and a diameter of at least 20 cm are used for the construction of anchored logs (cf. Figure 19). The logs are anchored in the stable subsoil by means of dowels or steel cables (for example deadman anchors or earth anchors) and should be covered in the potential landslide body. The number of anchors depends on the log dimension and the individual foundation's load-bearing capacity. Works are generally carried out from bottom to top, which also allows excavated material from the upper log to be used to cover the lower log. This measure is particularly advantageous in steep and hard-to-access terrain.

Figure 18  
Illustration of the effect of wooden logs on shallow landslides (hatched area), which activates passive earth pressures at the log.

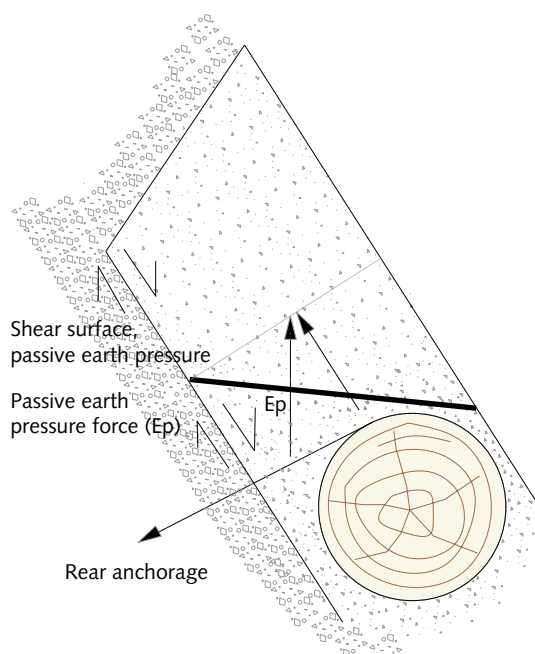

### 5.3.2 Slope grating

Slope grates are lattice constructions that increase the stiffness of a potential landslide mass and stabilise the slope primarily by distributing the compressive forces at the base of the slope. To fulfil this function, the slope grating must be built into the potential landslide mass and not just be placed at the surface. This type of measure is not suitable for stabilising rotational slides or deep movements. Slope grating is often built as a complement to cribwalls in order to dissipate the compressive forces over the surface and selectively transfer them to the slope foot or into stable subsoil.



Figure 19 (left)  
Construction of rear-  
anchored wooden logs to  
stabilise an embankment.



Figure 20 (right)  
Construction of a slope  
grate for slope stabilisa-  
tion.



The construction is made of live (for smaller dimen-  
sions [49]) or dead logs, with diameters of approxi-  
mately 10–30 cm (cf. Figure 20). Tapered logs can  
also be inserted in the line of slope (longitudinal

logs), with the larger diameter directed at the slope  
foot. Longitudinal logs and transverse logs should  
be spaced 1,5–2 m (maximum 3 m). The transverse  
logs are supported by short logs in the line of

Figure 21  
Schematic of simple slope  
grating.

- 1 Foundation sill  
d = approx. 400 mm
- 2 Posts, d = approx.  
200 mm, length  
approx. 1,0–1,5 m
- 3 Lower longitudinal  
logs, continuous,  
spacing  $a = 1,5-2,0$  m,  
d = approx.  
200–300 mm
- 4 Upper longitudinal  
logs, intermittent,  
d = approx. 200 mm
- 5 Transverse logs,  
continuous,  
d = approx. 200 mm
- 6 Reinforcing bar,  
d = 12–18 mm
- 7 Rear anchorage  
L = 1,5–3,0 m
- 8 Complete covering

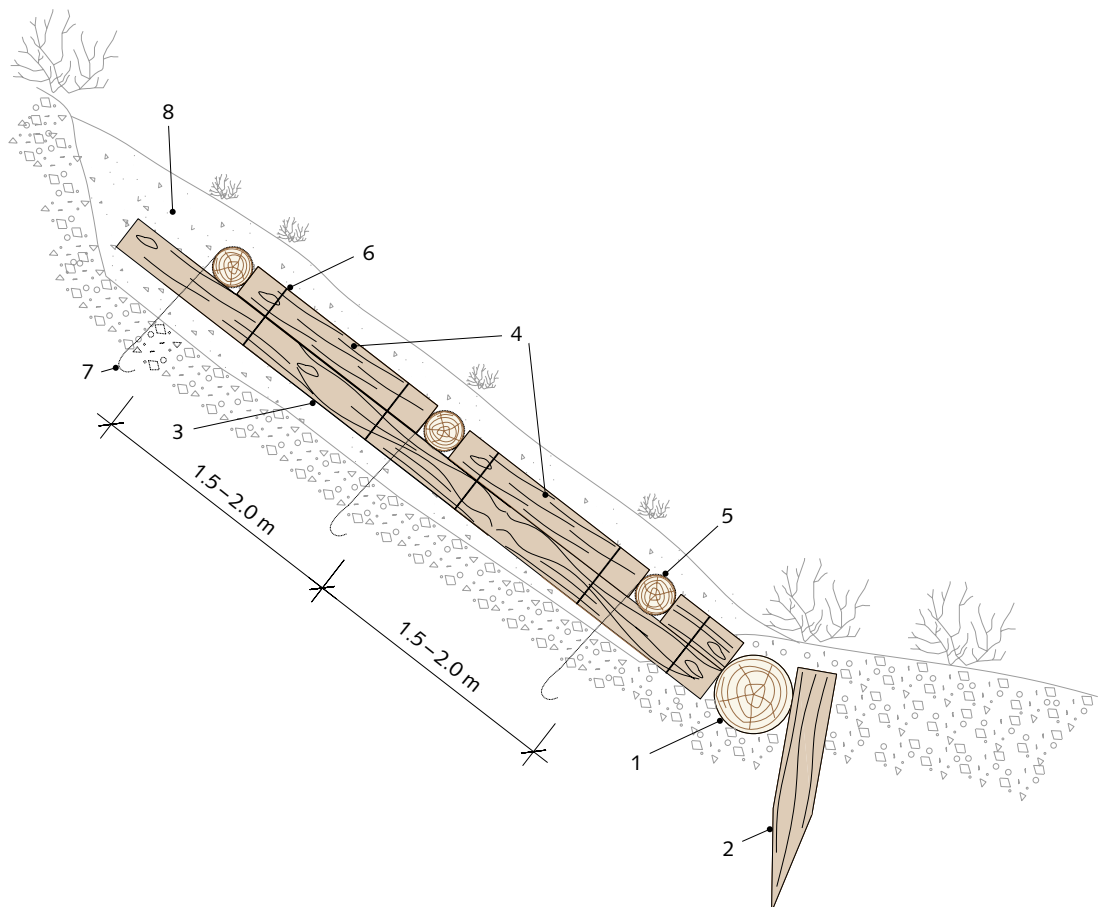

slope (upper longitudinal logs). Several layers of longitudinal and transverse logs can be installed, depending on the thickness of the potential landslide mass, but usually two layers are used (see Figure 21). During construction, brushlayers or hedge layers (rooted brushlayers) can be incorporated when infilling with soil. Alternatively, cuttings and/or seeds can be planted/sown afterwards. When using live material, work should be carried out during the dormant season (November to March). The application of live material simultaneously ensures that roots assume stabilising functions in the long term and very quickly protects against surface erosion (see also [50] and [51]).

Slope grates with lengths of up to approx. 15 m and a well-anchored base can be built without rear anchorage. For longer slopes or steep slopes (> angle of friction of the soil at which active earth pressure occurs), the slope grating must be fixed in the stable subsoil by means of dowels, reinforcing bars or anchors (e.g. expanding earth anchors or toggle earth anchors on steel bars or steel cables). Slope grating should not be built steeper than a maximum of 60°. Especially on steep slopes, the fill material must be well stabilised, with living material (cuttings or bare roots) being the most appropriate, or with geotextiles in exceptional cases. Lack of rear anchorage, poor overlapping of transverse logs and insufficient toe protection are the main causes of damage to this type of wooden construction.

### 5.3.3 Log cribwalls

Cribwalls are suitable for the selective stabilisation of slopes and embankments as well as for the remediation of smaller damaged areas. The basic principle of wooden crib construction in slope stabilisation is the same as for torrent control measures, and in this case, too, a distinction is made between single-walled and double-walled constructions (see Figure 35). Single-walled wooden cribs are susceptible to tilting and are therefore only used for structures of up to about 1–2 m in height. It is important to ensure that the transverse logs are well anchored in the substrate. Double-walled wooden cribs should have a maximum height of 5 m. [52]

These constructions either act against active earth pressures (steep slopes) or selectively stabilise shallow movements (creeping pressure), mostly in combination with slope grating. The function of the cribwalls is to transfer the forces acting on the up-

hill side above the foundation into the stable subsoil or into stable lateral areas. In this case, the wooden frame together with the backfill forms a composite structure and, from a static point of view, a relatively stable gravity retaining structure. The load-bearing safety is verified accordingly. However, the verification of the internal load-bearing safety is complex and is not verified by calculation. Instead, basic experiential design rules are applied. The impact of pore water pressure should be completely eliminated by drainage. These constructions act by their own weight (gravity retaining wall) or in combination with anchors. It is important to consider that the additional weight of the structure does not cause ground failure or deep instabilities. These constructions may also need to be anchored laterally in stable terrain.

The construction consists of longitudinal logs (other names: runner, sill, row) laid parallel to the slope or contour line and transverse logs (anchor logs, cribbing) laid perpendicular to the longitudinal logs. The transverse logs can be arranged on top of each other or alternating at distances of 1–3 m. The alternating arrangement of the transverse logs guarantees a better rigidity of the construction. Depending on the use, the diameter of the structural elements should be chosen such that the deflection of the individual elements does not affect the structure's utility (if challenged) and that the criteria of internal load-bearing safety are met (tensile, compressive and transverse compressive stresses, see standard SIA 265 [38]). If possible, diameters > 25 cm should be chosen so as to increase the structure's durability. [22] The longitudinal logs should be as long as possible to reduce the number of weak points in the construction. The distance between the longitudinal logs should not be greater than 3 m. To reduce deformation of the construction due to decomposition of the wood, the sapwood can be removed at the timbers' point of contact, depending on the timber species, so that heartwood lies on heartwood. Butt joints between the longitudinal logs are preferable (cf. Figure 22) as this variant is more durable and easier to construct. It is important to support the transverse logs at a distance of max. 0.75 m each on both sides of the joint. These supports can also be additionally fastened by means of construction staples (diameter 10–20 mm) or by doubling up the supports and bolting them right through. [15] Lap-jointing, however, is more complex and susceptible to decay.

Figure 22  
Illustration of the connection of longitudinal logs.

- A** Lap joint (not recommended)
- B** Butt joint
- 1 Longitudinal logs
- 2 Transverse logs
- 3 Lap joint
- 4 Butt joint
- 5 Nail (reinforcing bar)

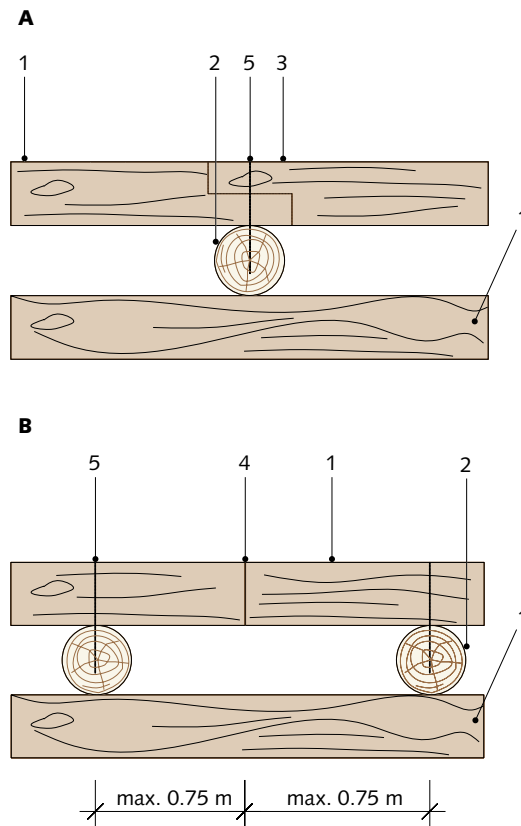

The joints between longitudinal and transverse logs are usually made with reinforcing bars (B500B reinforcing steel, cf. Figure 23), 12–18 mm in diameter and with a length greater than twice the diameter of the timber. These joints are particularly susceptible to wood-destroying processes. Iron released from the nails promotes fungal growth [22], so the use of galvanised nails is recommended where possible (see Figure 24). [20] Pre-drilling of nail holes is also recommended in order to reduce damage to the timber. However, the diameter of the hole should be smaller than the diameter of the nail so that sufficient skin friction remains. To reduce friction between the wood and the nails when driving them in, the nails can be dipped in biodegradable oil. Without pre-drilling, the pointed nails often run outwards along the growth rings, especially in the lower timbers. Moreover, the cribbing wood tends to split easily.

The dimensioning of a structure must meet the external safety requirements against creeping pressure or active earth pressure (safety against tilting, sliding and ground failure pursuant to standards SIA 260, 261, 267), as well as the criteria of internal load-bearing safety (standard SIA 265). Utility is ensured by means of using timber of sufficiently large diameters. The constructions described above meet these requirements in practice.

Figure 23 (left)  
Connection between transverse and longitudinal logs by means of a reinforcing bar.



Figure 24 (right)  
Ungalvanised and galvanised nails. Pre-drilling should be carried out even for sharpened nails.

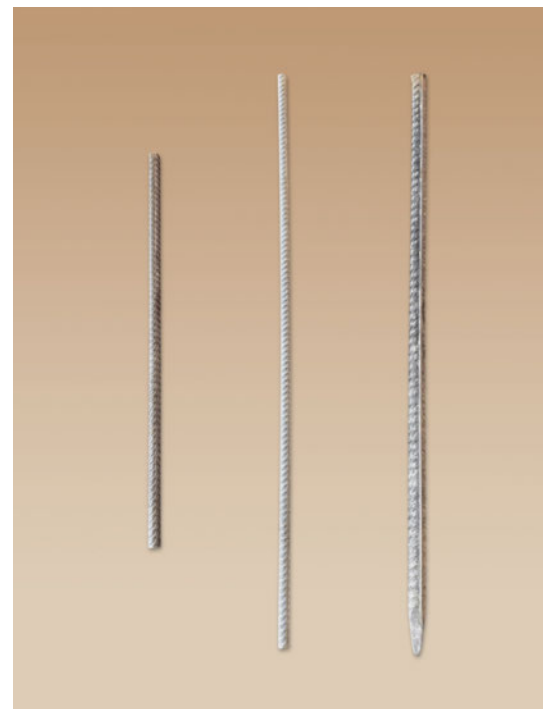

During construction, the foundation is dug down to the stable subsoil, usually with a walking excavator with integrated winch. After excavation and during construction, the slope must be temporarily secured in the case of deep excavations (e.g. with supports or with excavator bucket and metal grid). First, the lowest row of longitudinal logs is laid. Depending on the application, the foundation level may be inclined backwards by about 5–15° to increase safety against sliding.

If the subsoil at the foundation is not sufficiently stable against sliding, the bottom row can be anchored (for example by means of expanding earth anchors, toggle earth anchors or deadman anchors) or stabilised by means of railway sleepers driven into the ground. [20]

It is important to ensure that the construction is well drained. This can be ensured by using permeable backfill or promoted by installing a French drain behind the first, uphill longitudinal timber row. Following the installation of a layer of longitudinal and transverse logs, the backfill material is compacted or, if cuttings or bare-rooted plants are used, merely firmed down (promoting root penetration).

If the backfill material is prone to erosion, the gaps between the longitudinal logs must be closed off from the inside, using rocks (cf. Figure 25 and Figure 27) or infill logs (cf. Figure 26) (geotextiles or strands of sheep's wool, an insulation product, may also be used). The ends of the transverse logs can be sawn off, at least 20 cm away from the longitudinal logs, to prevent splitting.

Figure 25 (left)  
Using rocks as infill material.



Figure 26 (right)  
Using log layers as infill material.



Logs should be inserted as fresh as possible and kept damp. Shading by plants or covers can be beneficial for durability. The effect of covers depends strongly on the type and permeability of the soil. In clayey soils, where the wooden cribwalls are installed in permanently reductive conditions, the wood can last for exceptionally long periods (more than 100 years). Under these conditions, however, no complementary effect of the roots in the deeper

soil horizons is to be expected. In contrast, the installation of wooden cribwalls in permeable and biologically active soil horizons promotes the rapid decomposition of wood; the vegetation however can then assume a stabilising function more effectively. If wooden cribwalls are not covered, it must be expected that these structures will show signs of decay within a few years.

The advantage of wooden cribwalls is their elastic structure, which can adapt well to slope deformations and settlement processes. Their lower weight compared to concrete or rock structures reduces the possibility of ground failure. Additionally, wooden cribwalls are cheaper than other constructions (e.g. made of concrete), mainly owing to the fact that they are built from local material (see Chapter 8). Construction site logistics are also often simpler than for other construction methods, whereby the experience of the local construction team is a decisive factor. Another advantage of such structures is that no demolition will be required.

Figure 27  
Example of an approximately 30-year-old wooden crib with stone infill, used to stabilise a road embankment.



#### 5.4 Limits to the use of wooden structures

Restrictions on the use of timber in slope stabilisation are mainly due to aspects of load-bearing safety, usability and durability.

As far as the load-bearing safety of timber structures is concerned, the design constraints are defined by considerations of internal and external load-bearing safety. For the internal load-bearing safety of wooden cribs, particular attention must be paid to the transverse compressive stress in the area of the connections between longitudinal logs and transverse logs (cribbing). The permissible compressive strength perpendicular to the direction of the wood fibres can be a limiting factor in this case, imposing a height limit for the wooden cribs. Another limiting aspect of the internal load-bearing safety of wooden structures (e.g. wooden cribs) is the stress due to the line load or the pressure exerted by the backfill (e.g. earth pressure at rest with soil backfill). This stresses the load-bearing safety both within the timber components and the connections between the components. With regard to the external load-bearing safety, it should be noted that timber structures have a lower weight than structures made of concrete, for example. This aspect can be a limiting factor, especially when it comes to structures that have to provide a stabilis-

ing function solely by means of their own weight (e.g. retaining walls). Another limiting factor is the steepness of the terrain, if it means that retaining structures can only be erected with difficulty or at great expense, mainly because of the large excavation volume required for the structures' foundations. In such cases, solutions such as rear-anchored works (e.g. palisade walls) are an option.

The usability of some structures is defined by the deformations they can undergo due to external stresses or their own weight. In the case of timber constructions for slope stabilisation, deformations are usually not problematic. However, in the case of structures used for slope stabilisation along forest roads (cf. Figure 28) these deformations can limit their functionality (especially in the case of valley-side structures that are under great strain from traffic loads).

As already mentioned in Chapter 2, the durability of wood depends on many factors and must be assessed on a case-by-case basis. Considering the significant uncertainties in predicting durability, it is important to have an inspection and maintenance plan for timber structures and to complement their construction with bioengineering measures. In general, it is reasonable to assume that timber structures for slope rehabilitation have a durability of 10–30 years. Figure 29 and Figure 30 show a wooden crib that is approx. 30 years old, which has reached the limitations of this type of structure: The wood is in part completely rotten and partly compressed under its own weight. The vegetation cover is insufficient to take over mechanical functions.

Moreover, maintenance requirements may impose limits. The more difficult the site conditions, the more costly the maintenance work, which needs to be carried out over several years and with increasing intensity.

Figure 28  
Slope stabilisation  
on a forest road.



Figure 29 (left)  
Double-walled wooden cribs showing signs of deficiencies in terms of load-bearing safety after approx. 30 years. A vegetated and gentler incline would likely be more successful.



Figure 30 (right)  
Decayed and compressed cross-sections of the wooden crib's transverse logs.

### 5.5 Complementary effect of bioengineering construction measures

Due to their limited durability, timber constructions for slope stabilisation are usually to be considered non-permanent measures. On the other hand, in most cases the functions of these structures can be well compensated for by the addition of vegetation and the effects thereof.

The vegetation's canopy effect can greatly reduce the erosive effect of raindrops (splash erosion) a few weeks to months (for grasses) after work completion. In addition, the formation of a root network close to the surface (a few centimetres deep)

gives greater stability to the soil particles (protection against interrill erosion and rill erosion). The increase in roughness due to vegetation reduces runoff velocity and promotes water infiltration, which in turn promotes vegetation establishment. All these effects reduce surface and gully erosion (see Chapter 4). Figure 31 shows the vegetation development over time on a slope with wooden structures designed to protect against surface and gully erosion (terraces, water drainage channel, wooden check dams).

Figure 31  
Vegetation development over time on a slope covered with wooden control structures in Arieschbach, Grisons, Switzerland. Left: 1998, Centre: 2005, Right: 2017.



The growth of shrubs and trees enhances the vegetation's mechanical effects over time, with the dynamics of root reinforcement being of particular importance in stabilising shallow landslides. The dynamics of root reinforcement vary by site and tree species, but can take over the stabilising effects of slope grating or wooden cribs within 20–30 years on favourable sites. [53] The interaction between the diminishing functionality of wooden control structures and the increasing effect of roots is conceptually illustrated in Figure 32. This shows how the duration of functionality can be influenced by the dimensioning of the timber structures (diameter and spacing of longitudinal logs, timber species) and how, at the same time, the growth and structure of the vegetation determines the increase in root reinforcement. In bioengineering construc-

tion, a quantification of the development of root reinforcement over time is an important parameter for assessing the long-term functionality of slope stabilisation works and a quantitative cost-benefit analysis. [54]

An additional stabilising effect on many slope processes is exerted by the effects of the vegetation on the water regime, such as evapotranspiration (increase in apparent cohesion during dry periods) or the formation of draining preferential flow paths parallel to the slope (analogous to fascines). The choice of tree species can also influence the chemical condition of the soil. In particular, the composition of plant litter can influence the soil biological activity and thus control soil-forming processes, which can ultimately have a positive effect on slope stability.

Figure 32  
Conceptual representation of the temporal interaction of wooden control structures (diminishing) and lateral root reinforcement (increasing).

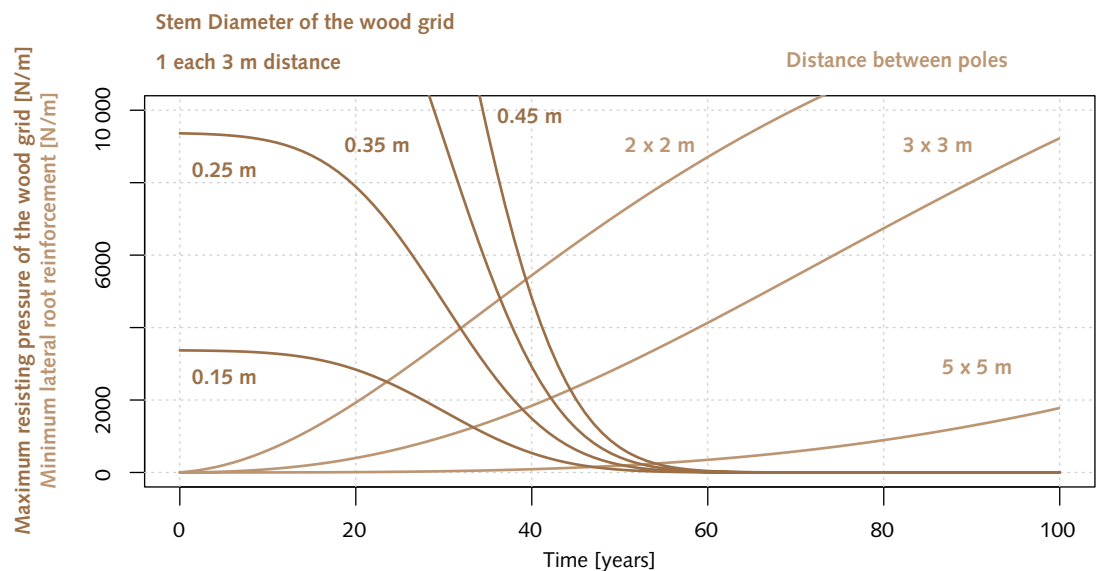

Photo in 2011 (left)  
Construction of slope grating with log diameters of 15 cm and a distance between the logs of 2 × 2 m.



Photo in 2015 (right)  
Development of vegetation after 4 years.



An estimate of the possible rooting depth is often a decisive aspect for the successful and long-term use of bioengineering construction measures. This is generally dependent on the tree species, soil type and climate. Especially the change in soil water content over time is an important factor for root distribution. [55] In permeable soils, roots can reach depths of several metres if the upper horizons remain dry. In contrast, shallow root systems tend to develop in humid near-surface soil horizons. Permanently saturated and clayey soil horizons are limiting for root growth (pseudogleys and gleys). Covered wooden cribs can last for a long time in such soils (up to 100 years, see also Chapter 2), but roots cannot be expected to take over their function. In structures that stabilise the first 1–2 m of

depth in a permeable soil, the durability of wood is greatly reduced; under suitable conditions, however, the effects of vegetation can well replace the structures' stabilising function. Soil chemical properties (e.g. pH), light conditions and snow are other important factors that can be critical for vegetation establishment. The influence of browsing game animals must also be taken into account and possibly limited by means of additional measures (e.g. with fencing). Furthermore, the impacts of invasive neophytes should be taken into account and countered with measures in the design and maintenance of the structures (e.g. reforestation with competitive tree species or removal of unfavourable tree species).



## 6 Timber for torrent control

In torrent control, timber is mainly used in the form of round logs for bed protection in dam structures (transverse structures) and streambank retaining structures (longitudinal structures).

### 6.1 Processes and impacts

The above-mentioned structures act against the erosive properties of the flow processes in streams and rivers (see Chapter 6.2). They are under stress from earth and water pressures. For the design of dam structures, the water pressures from the lower edge of the structure to the surface of the relevant water level are applied. Since wooden check dams have a permeable structure, the static water pressures can be mitigated. On wing walls that extend from the streambed into the stream bank to the sides of the discharge section, dynamic water pressures also impact all parts in the line of approach. The magnitude of the water pressures above the stream bed depends on the flow height, the density of the flow process and the velocity.

For the standardised determination of the characteristics of the discharge (flow process), [56] distinguishes three groups of flow processes (flood, solids transport and debris flows) as set out in Table 3. The parameters given there are reference values.

While flood discharges can occur at any streambed slopes, they are particularly frequent in shallow stretches of streams (less than 2% streambed slope). In steeper stretches (mostly torrents), flow processes tend to be characterised by a higher proportion of solids, meaning that the design process must take into account not only the existing water volume but also the mobilisable sources of debris and sediment (stream bed, lateral breaks, displaced masses, etc.). The design and dimensioning can therefore only be determined by a detailed analysis of the stream's catchment area. Flow velocities for calculating dynamic water pressures are taken from discharge simulations. As a guideline, velocities up to 2 m/s occur in flood discharges and shallow stretches of streams (below 2% streambed slope); in steep stretches (up to 10%) average flow velocities of up to 5 m/s are possible. Further details on the impacts and the process of dimensioning a barrier can be found in [57], [58], [32] and [40].

Table 3  
Standardised groups of flow processes and key parameters according to [56] and [33].

Process parameters	Flow process				
	Flood	Sediment load discharge		Debris flow	
		fluvatile	debris-like	grein flow	mudflow
Density $\rho$ , in kg/m <sup>3</sup>	1000	1000–1300	1300–1700	1700–2000	2000–2300
Process-dependent average speed $v$ , in m/s	Determination pursuant to hydraulic model often 0–5		3–5	3–6	5–10

## 6.2 Overview and function of dam structures

Dam structures (transverse structures) fulfil the function of stabilisation/consolidation (according to [56]). Stabilisation includes all measures that serve to secure the bed and the banks, including the lateral slopes, in their existing position and to protect them against lateral and deep erosion (Figure 33 and Figure 43). By using dams to create stepped benching in the streambed, the bed slope is reduced and free spillways (falls) are formed. This results in reduced flow velocity and a reduction in the energy of the flow process. This is associated

with a reduction in bedload transport capacity, which leads either to a reduction in erosion capacity or to the temporary deposition (sedimentation) of transported solids. These regularities influence the angle of the depositional grade (cf. Figure 34). If, at the same time, the stability of the lateral slopes is improved by raising the channel bed by means of dams, this is referred to as consolidation. Wooden consolidation dams can be used for flood discharge and, with appropriate construction, for debris like sediment load a scourge.

Figure 33  
Schematic diagram  
of the stabilisation  
function achieved by  
means of a chain of check  
dams.

- 1 Transverse structure (dam)
- 2 Spillway
- 3 Scour
- 4 Energy conversion
- 5 Level control in the streambed
- 6 Slope stabilisation

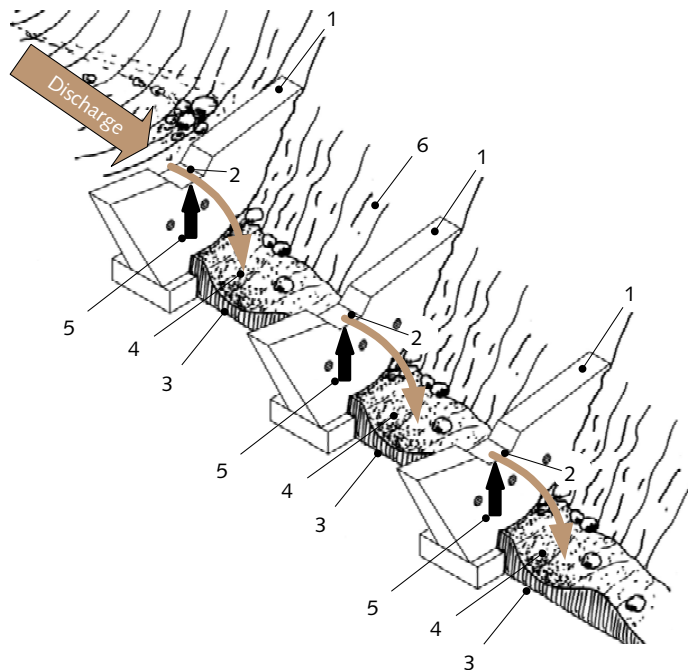

## 6.3 Construction and application of wooden dam structures

### 6.3.1 General design rules for wooden check dams

Dams (transverse structures) are to be arranged perpendicular to the direction of flow, where possible. The discharge sections are to be hydraulically designed for the design discharge. For reasons of stability, the wing walls must not overflow under design flow conditions. To further support stability, it is recommended in [56] that the wing wall tops be equipped with a wing taper of at least 10% for floods or fluvial sediment load discharge and at least 15% for debris-like sediment load discharge, but not less than the maximum depositional grade in the stream section under consideration.

In most cases, wooden check dams are installed as a chain of check dams (series of regularly arranged transverse structures) (cf. Figure 33 and Figure 43). Compared to the gradient of the unobstructed torrent, a smaller gradient occurs between the chain's individual dams. This depositional grade depends on the particle-size distribution in the stream bed and the type of flow process. The depositional grade can be calculated pursuant to [32] p. 32 ff. When designing the chain of dams (cf. Figure 34), an optimum between dam height  $H_s$  and dam spacing  $L$  must be found. The distance  $L$  between the dams within a chain must at least correspond to the length of the scour  $L_k$  (nappe). Scour lengths can be

Figure 34  
Longitudinal section  
of a chain of check dams.

- 1 Original bed slope
- 2 Minimum depositional grade
- 3 Maximum depositional grade
- 4 Wooden check dam (schematic)
- 5 Siltation area
- 6 Energy conversion
- 7 Scour
- 8 Scouring ridge
- 9 Overfall

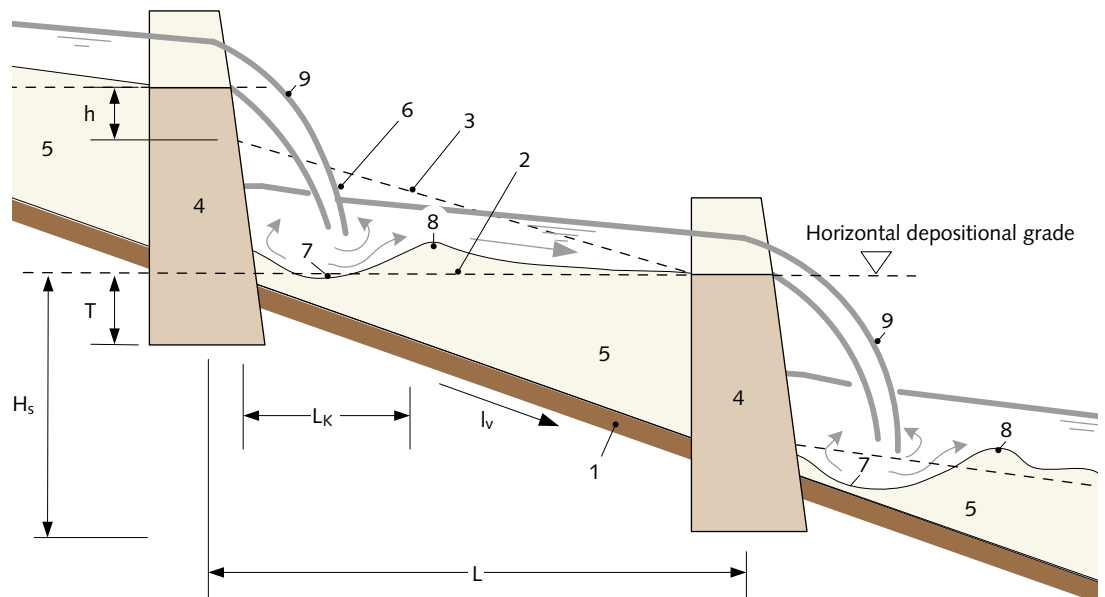

calculated according to hydraulic laws (e.g. parabolic throwing). Information on the calculation can be found in [32] and [59]. The required dam height results from the intersection between the original bed and the assumed minimum depositional grade between the dams. The dam foundation must reach to a depth of 1–1.5 m ( $T$ ) below this intersection point. A very safe assumption would be a horizontal depositional grade. The maximum possible depositional grade has to be estimated. The discharge section of the dam above must protrude at least 50 cm ( $h$ ) from the stream bed, as otherwise discharge concentration may no longer be assured.

### 6.3.2 Construction of cribwalls

A wooden crib consists of interconnected longitudinal and transverse logs (cribbing; cf. Figure 35 and Figure 38). Material is filled into the cavity formed by this box. This backfill material increases the dead weight of the wooden crib construction and thus generates a rotating moment against the impacts of earth and water pressures. These constructions therefore act as gravity retaining walls or dams. In the case of double-walled dam structures, if unavoidable butt joints of the longitudinal logs are offset and the dam's anchoring in its lateral flanks is sufficiently load-bearing, the wooden crib can also exert a horizontal load-bearing effect. Wooden cribwalls are commonly constructed from longitudinal logs with diameters of 20–50 cm (often 28–36 cm), mainly softwood logs from the construction site's immediate vicinity. In exceptional cases, timbers harvested at more distant locations, such as larch or Douglas fir, are used for

reasons of durability. Nodal connections between longitudinal and transverse logs must be load-bearing in structure. According to [32], this can be achieved by means of through bolts or threaded rods with nuts on both ends, or more simply with nails made of B500B reinforcing steel. The nails are 0.6–1 m in length and are inserted by means of hydraulic nail guns, in some instances with pre-drilling. Pre-drilling prevents the wood from splitting. This is important given that the service life of a wooden construction essentially depends on the quality of its individual joints and connections.

Since part of the shear stress is absorbed by friction as a result of the vertical pressure, each log placed on top must rest without fluffing and be nailed down to the log below at each crossing point. Practitioners recommend to only rout out the underside of the cribbing and only in exceptional cases. The maximum routing depth should not exceed  $\frac{1}{4}$  of the cribbing logs' diameter. This is because any damage to the wood fibres constitutes a mechanical weakening and a further entry point for wood-decaying organisms. It is generally important to ensure a clean, 'lattice-like' connection of all wooden components.

Longitudinal log joints should be as simple as possible (see Figure 22). For butt joints, it is advantageous to place a transverse log to the left and right of the joint. According to [32], the transverse logs should be arranged one above the other at least in the area of the discharge section so as to minimise the surface area exposed to falling rocks (cf. Figure 37).

Depending on the number of levels of longitudinal logs, a distinction is made between single-wall,

Figure 35  
Common construction  
types of cribwalls.

- A** single-wall  
**B** double-wall  
**C** triple-wall

For detail A see Figure 36,  
for detail B see Figure 41.

- 1 Longitudinal log  
2 Transverse log  
(cribbing)  
3 Backfill  
4 Infill  
5 Tightly packed floor

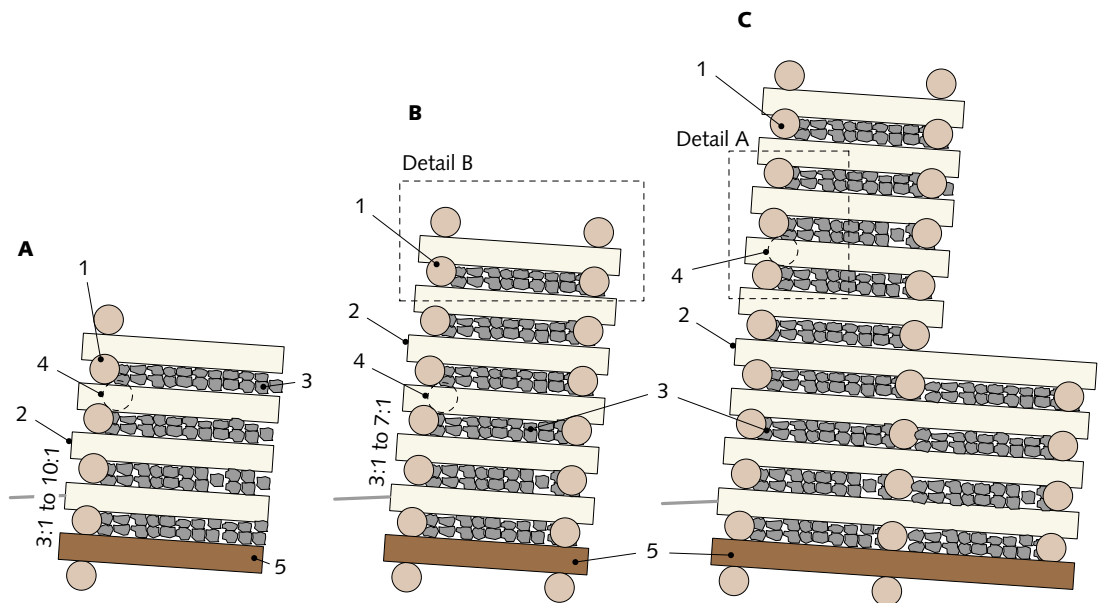

double-wall and multi-wall wooden cribs (cf. Figure 35). Common construction heights applied in practice are listed in Chapter 6.5.

Single-wall structures consist of longitudinal logs anchored in the ground by means of cribbing (see Figure 35 A). Transverse logs secured by means of driven piles (vertical posts) have proved not to be particularly durable in practice. On the air-side, the dams are designed with an inclination of up to 10:1. Double-walled wooden cribs consist of two parallel levels of longitudinal logs connected by transverse logs (cribbing) (cf. Figure 35 B). According to [32], air-side inclinations of up to 7:1 are structurally prudent. Single- and double-walled constructions often have a base width of 2 m with a height to the lower edge of the discharge section of 2–3 m. The greatest heights can be achieved with three-walled wooden cribs (cf. Figure 35 C). Air-side dam inclinations between 3:1 and 5:1 provide optimal wetting of the air-side by water run-off, which tends to increase the service life.

Frontal view schematic diagrams are given in Figure 37 by type of wing wall. These apply to all types of wooden cribwalls described above.

In practice, wooden check dams tend to be used in trenches that are difficult to access, as the logs can be relatively easily transported. The linear form of

channels facilitates the use of mobile-rope cranes in that the installation of one rope line can usually serve the construction of several dams. Nowadays, construction is mostly carried out with the support of walking excavators with integrated winches. Due to the brief construction time, wooden check dams are also used as an immediate measure directly following events.

### 6.3.3 Foundations

According to [15], wooden cribwalls must have as their foundation a cleanly levelled and load-bearing support surface that is inclined perpendicular to the crib. A bottom longitudinal timber layer is placed on this foundation. To increase robustness, a tightly packed floor layer (German: *Prügelboden*) may be installed above it. This consists of round timbers placed side by side and rests on a longitudinal log on the air-side. Such a tightly packed 'floor' prevents the backfill of the wooden crib from being washed out and considerably reduces the risk of internal erosion. Where the subsoil is rather cohesive and clay/silt-containing backfill is used in combination with suitable blocks, the packed floor layer can be dispensed with.

### 6.3.4 Securing the dam's toe scour zone

Due to the often steep terrain, which does not allow sufficient space for the formation of a scour basin, the dam's toe scour zone must be secured in many cases. In the case of wooden check dams, bed aprons made from armourstones (cf. Figure 38), subsidiary dams, extended tightly packed 'floors' on the air-side (cf. Figure 43) or horizontal wooden grating with stone infill are commonly used. Laterally, the scours can be bordered by wooden cribwalls (cf. Figure 43) or riprapping.

### 6.3.5 Backfill and infill

An empty wooden crib has a very low stiffness because, from a statics perspective, the nodes are joints. The system only acquires the requisite stiffness by the cavities being filled with coarse stones and/or the excavated material (if suitable). Ideally, potential flow paths through the dam are blocked with clayey soil. Where there is a risk that the backfill may be washed out, cracks can be closed with sheep's wool plait. The infills of a wooden crib can be made of wood or stone inserts (cf. Figure 36 and Figure 38). The advantage of stone

infill is the higher stiffness and longer service life. The stones are installed in the infill in such a way that they cannot drop out (cf. Figure 36 A). According to [15], the first layer should consist of stones that can wedge in the opening, and a continuous drystone wall should be erected behind the infill stones. Since stone infill entails manual labour, for cost reasons this method is now rarely used.

The infill with timber parallel to the longitudinal log can be achieved in two ways (cf. Figure 36 B, C and Figure 38). In the first variant, logs of the same diameter as the openings to be filled are used (cf. Figure 36 B). These roundwood logs are nailed to the longitudinal logs. The second variant uses logs of a larger diameter than the openings to be closed and fills the opening from behind (cf. Figure 36 C). While the amount of nailing required is considerably lower in this variant, the inserted logs may shift due to subsequent settling. The sealing with sheep's wool plait of gaps in timber-filled wooden cribwalls in soils rich in fine particles is easier than fitting a geotextile. A further variant is infill with logs parallel to the transverse logs (see Figure 36 D, Gruyère system).

Figure 36  
Infill of cribwalls.  
Detail from Figure 35.

- A** Infill with rocks
  - B and C** Infill variants using log layers parallel to the longitudinal logs
  - D** Infill using split logs (Gruyère system)
- 1 Longitudinal log
  - 2 Transverse log (cribbing)
  - 3 Stones (blocks)
  - 4 Roundwood log
  - 5 Drystone wall structure
  - 6 Backfill
  - 7 Roundwood or split logs

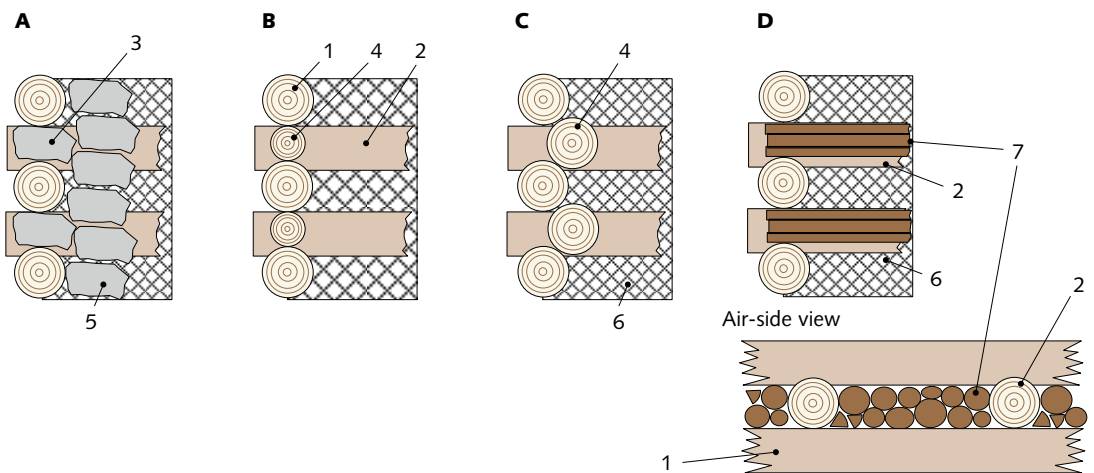
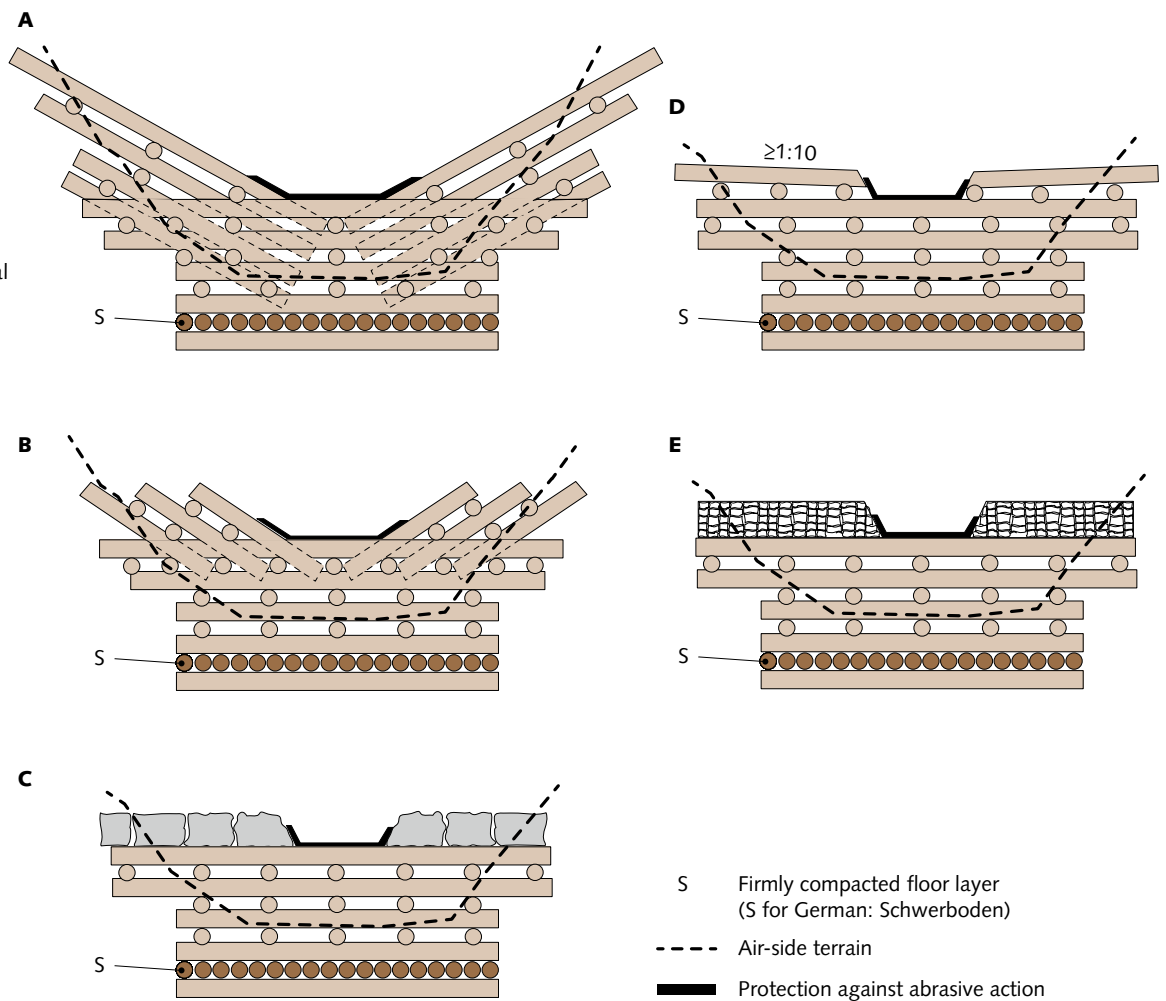

Figure 37  
Schematic of wing wall construction, showing the air-side views of wooden check dams.

- A and B** Inserted wings  
**C** Blockstone wing walls  
**D** Inclined and horizontal wooden wing walls  
**E** Wing walls made of gabions



### 6.3.6 Wing walls

In order to focus the discharge in the middle of the stream, a discharge section must be formed by means of wing walls (cf. Figure 37). There are a number of different wing wall designs.

In current practice, wooden wings are primarily used. These are often erected in the form of cribwalls (cf. Figure 37 A, B, D and Figure 39 A). For increased resistance, the wings can also be extended a little upstream. A connection to the dam located above is also an option. A higher resistance against shearing is offered by inserted wings as used in Austria (recommended design for streams that are prone to debris-flow). In this variant, as shown in Figure 37 B, the logs constituting the wings are inserted between the longitudinal and

transverse logs. For narrower streams, the wings can also be constructed as shown in Figure 37 A.

In order to counteract the problem of the shortened service life of timber structures in the area of embedding, the wing wall can be constructed from gabions (cf. Figure 37 E) or armourstones (cf. Figure 37 C and Figure 38). It should be noted however that due to the weaker connection to the dam body, gabions can more easily be pushed off the dam by discharging water.

The wing walls or longitudinal logs should be laterally anchored 1.2–1.5 m deep (at least 2 m where there is debris-like sediment load discharge) into the flanks.

Figure 38

Left: Log crib check dam with wing walls made of armourstones and roundwood log infill. Right: Toe scour zone protection constructed from armourstones.

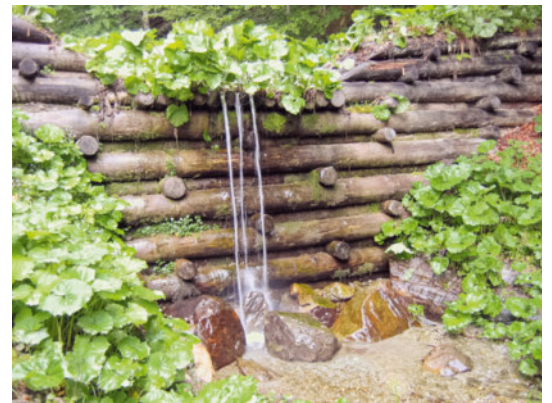

Figure 39

Examples from Austria.

- A** Log crib check dams with slanted wing walls
- B** with inserted wings
- C** Tightly packed logs in the discharge section
- D** Three-walled log crib check dam



Three-walled log crib check dams, as shown in Figure 39 D, are extreme structures for special applications. In this case, a wooden construction was chosen because the slopes at the construction site are still sliding. Only after the slopes have consolidated over a period of about 20–30 years (which roughly corresponds to the wooden control struc-

ture's service life) will a concrete barrier be erected in front of it. The use of calibrated timber, as shown in Figure 39, is not common in Switzerland. The advantages of using calibrated timber are easier assembly, accuracy of fit and uniformity of the structure. However, the additional processing and transport costs discourage this approach.

### 6.3.7 Discharge section

The lower edge of the discharge section should be horizontal to ensure even wetting of the dam's air-side. The discharge sections of wooden check dams are subject to abrasion even during occasional bed-load discharge (see Figure 40). To increase the service life, discharge sections can be equipped with continuous protection against abrasive action. The most common type of abrasion protection is that using roundwood logs (cf. Figure 41 A, Figure 39 A–D and Figure 42). Furthermore, the top of the uppermost crib can be paved with flat rocks

(cf. Figure 41 B and Figure 40). A geotextile carpet, extending upstream, can also be installed underneath. As the longitudinal logs are unprotected here, a second longitudinal log should be placed at the front edge (cf. Figure 41 B). The crest in the area of the discharge section can also be covered in dressed stone (or concrete elements, Figure 41 C). With all covers it is important that they do not protrude air-side over the longitudinal logs, as otherwise they prevent the permanent wetting of the dam's front side by the discharge.

Figure 40  
Infill with stones: Wooden check dam after exposure to debris flows.



Figure 41  
Execution of the discharge sections. Detail B from Figure 35.

- A** Cover made of roundwood logs
- B** Paving
- C** Dressed crest rocks
- 1 Longitudinal logs
- 2 Transverse logs (cribbing)
- 3 Roundwood cover
- 4 Flat rocks
- 5 Crest rocks
- 6 Extended roundwood logs
- 7 Geotextile
- 8 Siltation

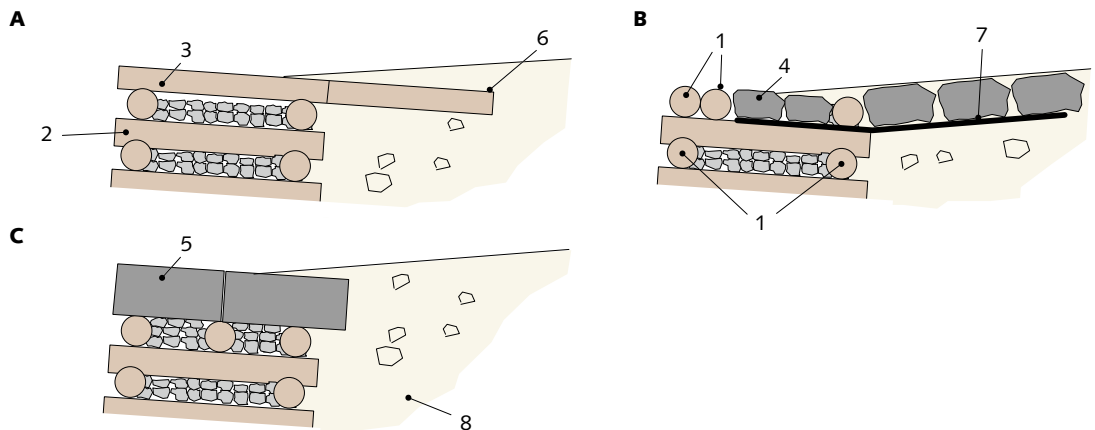



Figure 42

Design of the discharge section with covers made of roundwood log. The roundwood cover projects far and thus protects the log layers below it well against abrasion. However, this entails less good moistening, with the possible result of unfavourable moisture conditions in the wood in terms of biological decomposition.



### 6.3.8 Designs for higher loads

Wooden check dams are usually not stable when exposed to debris flows. Therefore, dams are often constructed from other materials. However, the resistance of wooden structures to debris-like sediment load discharge can be significantly increased by skilful design. In general, protruding parts in the

drainage area should be avoided (see Figure 40). Moreover, the dam's toe scour zone must be secured against flow processes with higher solids contents (see Chapter 6.3.4). Dams that are frictionally connected to the firmly packed floor on the air and water sides via the wing walls as well as at the streambed (connected chain of check dams, cf. Figure 43) have proven to be particularly resistant. Inserted wings should be used (see Chapter 6.3.4). It is important that the wings merge seamlessly into the guide walls and do not protrude. Discharge sections covered with logs have proven to be highly resistant, especially if they are extended upstream and connected to the dam above. According to [32], this can provide additional rear anchorage. Such a solution is out of the question if significant ground consolidation is yet to be expected in the siltation area. With this construction, however, one must be aware that later maintenance requires more effort, as interconnected wooden parts are difficult to replace.

Figure 43

Connected chain of check dams.



## 6.4 Construction of longitudinal structures made of wood

The construction of longitudinal structures (streambank retaining walls) follows the same principles as set out in Chapter 5.3.3. However, deviating from these approaches, infills (cf. Chapter 6.3.5) are always to be placed between the longitudinal logs, or a largely erosion-resistant material is to be used as backfill in combination with planted vege-

tation. As for dams, a firmly packed floor should be installed at the bottom of the embankment as described in Chapter 6.3.3. Streambank retaining walls should be anchored 1 m below the middle streambed level. Single- and double-walled wooden cribs are used (cf. Chapter 6.3.2).

---

### 6.5 Limits to the use of wooden structures

The geometry is defined by the dam length (stream width) and the dam height. The maximum possible construction heights of transverse and longitudinal structures are based on the construction type of the cribwalls. Single-walled wooden cribs can be constructed to a height of 1.5 m, and up to 2 m under optimum conditions. With careful construction, double-walled wooden cribs can reach a height of up to 4 m, and 5 m under particularly favourable conditions. To minimise the effects of dam failure, the heights of the structures should be kept as low as possible.

Maximum feasible widths are determined by the available log lengths. Six metres is a common length. Single-walled wooden cribs are limited by

these lengths. With double- and triple-walled systems, the butt joints can be staggered on the stream-side and air-side.

Favourable environmental conditions for wooden check dams are shady, permanently damp/wet sites. In frequently sun-exposed and regularly drying gullies, timber structures have a rather short useful life (often only a few years). Apart from this, the areas of lateral anchoring (zone of alternating humidity) are always a limiting factor for the service life, as environmental conditions in these areas are optimal for fungal growth (cf. also Chapter 2). Moreover, experience has shown that wooden check dams are generally unsuitable for sandy, erosion-prone soils.

## 7 Timber for protection against avalanches and snow movements

In avalanche control, wood is used particularly for temporary supporting structures and for measures to counteract gliding snow (stakes, tripods and

wooden logs). Wood is also used for snowdrift control structures and, occasionally, for avalanche deflectors.

### 7.1 Processes and impacts

Avalanches are rapid mass movements that occur in mountains all over the world wherever there is seasonal snow cover. Avalanche disasters have claimed human lives over and over again throughout history. Settlement patterns in mountain areas have been determined by efforts to abandon hazard zones or erect control structures (cf. Figure 44). Avalanches arise when an entire snow slab is released across a large area of the snowpack and breaks down into individual, more or less large clods that remain in contact with the ground while moving. Depending upon the properties of the snow and the topography of the terrain, an avalanche can be dominated by the dense-flow proportion or the powder-cloud proportion. Sites prone to avalanche releases typically have slope inclinations of 30–50°. The size of an avalanche can vary widely: it ranges from a slide with a volume of 100 m<sup>3</sup> to an extremely large avalanche with a volume of several hundred thousand cubic metres and a path of several kilometres. Once released, snow masses quickly reach speeds of 10–40 m/s. The density of a dense-flow avalanche is similar to that of the natural snowpack and is around 300 kg/m<sup>3</sup>. Avalanches are mostly initiated by strong snowfall in stormy weather or by periods

of warm weather. The pressure exerted by an avalanche depends upon the type of snow, the volume and the speed. Large avalanches can exert dynamic pressures of more than 100 kN/m<sup>2</sup> and cause major destruction. [60]

Gliding snow, in contrast, is a steady, slow movement of the entire snowpack on smooth slopes exposed to strong sunshine and with an inclination of at least 15°. Characteristic glide cracks known as 'fish mouths' (German: Fischmäuler) often form (cf. Figure 45). A smooth terrain surface and non-frozen soil promote gliding snow. Usually there is a wet, lubricating layer between the ground and the snowpack. If agricultural land on slopes is managed inappropriately, long-stemmed grass stands can amplify gliding snow. If an object such as a building is located in the gliding snowpack, the snow's movement is stopped locally. This leads to static snow pressures that are usually less than 20 kN/m<sup>2</sup>. Gliding snow can develop into a gliding avalanche, a rapid downward release of the entire snowpack. Gliding avalanches are a type of hazard that is hard to predict, e.g. for transport routes. Gliding snow and gliding avalanches will occur more frequently in future due to climate change.

Figure 44 (left)  
Deposits of a wet snow avalanche in January 2018.



Figure 45 (right)  
Due to the slow movement of the snowpack in the line of the slope, glide cracks ('fish mouths') have formed.



## 7.2 Overview and function of avalanche protection structures

Avalanche protection structures made of wood are employed mainly as temporary supporting structures and to provide protection against gliding snow. Wood is also used for snowdrift control structures and, more rarely, for avalanche deflections walls. Wooden structures in the form of snow fences or stakes were already built 150 years ago and count among the first technical protective measures in avalanche release zones. Today there are temporary supporting structures made of wood with an overall length of more than 200 km in Switzerland. The purpose of a supporting structure is to stabilise the snowpack such that the formation of avalanches is prevented as far as possible and small avalanches, which can never be prevented entirely, are arrested and brought to a standstill (cf. Figure 46). In the early days of avalanche control the supporting structure was often made of steel, and the grate beams of roundwood. Temporary sup-

porting structures are combined wherever possible with afforestation; the goal here is that the forest can adopt the protective function within the structures' anticipated service lives of 30–50 years. Compared to permanent supporting structures made of steel, it is an advantage of avalanche structures made of wood that later forest management activities are easier and there is usually no need to remove the structures after the end of their service lives. In view of their limited service lives and structure heights, temporary supporting structures are employed mainly in avalanche release zones below the forest line. Further typical sites are smaller release zones in settlement areas or above transport lines, windthrow areas, and larger regeneration areas in forested release zones. If load-bearing specifications are stricter or later afforestation is improbable, structures combining wood and steel are also used.

Figure 46 (left)  
Wooden snow rake  
in an afforestation area.



Figure 47 (right)  
Tripods on a slope prone  
to gliding snow  
in a settlement area.



Wood has become the predominant building material for measures to protect against gliding snow (cf. Figure 47). Steel or aluminium are only used in exceptional cases. Measures to protect against gliding snow increase the roughness of the ground in order that the snowpack interlocks better with it and no longer slides downhill. Measures include stakes, wooden logs and tripods. Because such dispersed measures have smaller dimensions than supporting structures, they only exert a local retaining effect. For them to be deployed successfully, they must therefore be erected across broad areas. Otherwise they can be overloaded and be destroyed. Measures to protect against gliding snow can be combined with temporary supporting structures, particularly at locations where young plants need additional protection. Frequent sites of

deployment include, beside afforestation projects, slopes with elevated gliding snow hazard above transport routes, ski runs and settlements.

Snowdrift control structures influence the site of deposition and the distribution of snow masses transported by the wind (cf. Figure 48). Snowdrift fences, often erected purely out of wood, are used to protect transport routes against snowdrift accumulation or to prevent excessive snow depth occurring in areas prone to avalanche release. For reasons of landscape protection or if avalanche impacts are small, a deflecting wedge can be installed that is made of wood (cf. Figure 49) or combines wood with steel. Such a wedge deflects the flowing avalanche to the left and right of the object that is to be protected.

Figure 48 (left)  
Snowdrift fence made of  
5 m long timber elements.



Figure 49 (right)  
An avalanche deflecting  
wedge made of timber  
protects a residential  
building.



### 7.3 Construction and application of avalanche protection structures made of wood

The first step in optimal planning of avalanche protection structures made of wood is to define the avalanche or gliding-snow problem, its possible causes and the consequences for people and assets. On that basis, the need for action and the protection goal of the measure are derived. Key points determining the selection of possible measures and the assessment of their feasibility are snow depth, topography, vegetation, slope inclination, ground roughness, vegetation growth conditions and subgrade conditions. An assessment of cost-effectiveness is also important. Using all this information, preplanning is performed or a construction project is elaborated. Unimpregnated structures are erected with heartwood-forming species such as sweet chestnut, robinia and oak. Where growth conditions are good, European larch can also be used. Spruce and fir would need to be impregnated; for environmental reasons this is no longer practised.

#### 7.3.1 Temporary supporting structures

The type of structure employed most frequently in Switzerland is the wooden snow rake with grate beams positioned perpendicular to the surface contour lines. Upslope, the grate transfers the snow pressure acting in the line of the slope to the sill, while downslope it is transferred to the purlin and posts (cf. Figure 50 and Figure 51). To increase the lateral stability of the structures, an angle brace is fitted between purlin and post. The individual roundwood elements are nailed down. Snow rakes are generally built as individual structures with a width of 4 m. Snow rakes are preferred over snow bridges because upslope anchoring of the sill across the entire width of the structure is easier, the inclined grate beams are less at risk of fungal infestation, and young growth suffers less fracture dam-

age by trunk deflection. The optimal inclination of the grate is  $15^\circ$  to a plane perpendicular to the slope; the optimal angle between post and grate is  $70^\circ$ . If the grate is positioned steeper, the upslope anchoring forces are greater. Wooden snow rakes can support a snowpack with a maximum depth of 3.4 m. Instructions and working plans are available for their erection [37]; these stipulate the requisite dimensions of building elements in accordance with the technical guideline [34] as a function of snow depth and slope inclination. Usually no project-specific static verification of internal and external load-bearing capacity is performed.

The load-bearing capacity of standard wooden snow rakes is based upon a glide factor of 1.8. The glide factor characterises ground roughness and greatly influences the degree of snow pressure. [34] Where ground roughness is small and glide factors larger, it is recommended to undertake additional measures to mitigate gliding snow, such as placing tripods between lines of rakes. For a snow depth of 3.4 m and slope inclination of  $45^\circ$  the diameter of the 3.30 m long grate beams is 20 cm, that of the purlin is 27 cm and that of the sill 20 cm (cf. Figure 50); all these specifications are at the edge of the structure. The 5 m long posts require a diameter of 24 cm in order not to buckle. It should be noted that unnecessarily large dimensions of the elements are detrimental in terms of wood moisture over their service life. The execution of the foundation of wooden snow rakes is very important to ensure a long service life. There are different variants depending upon the subgrade. Where the soil is shallow, the sill is anchored in the rock with wire rope anchors. In densely packed loose rock, ditch sills are used (cf. Figure 50); here the sill is buried about 80 cm deep. Where soils are not at risk of erosion, the sill can also be placed at the surface and secured by stakes. The post is fixed

Figure 50  
Schematic of SLF-type  
wooden snow rake with  
ditch sill anchoring.

- 1 Grate: roundwood  
( $d = 20$  cm,  
 $L = 330$  cm)
- 2 Post: roundwood  
( $d = 24$  cm,  
 $L = 500$  cm)
- 3 Purlin: roundwood  
( $d = 27$  cm,  
 $L = 400$  cm)
- 4 Sill: roundwood  
( $d = 20$  cm,  
 $L = 400$  cm)
- 5 Upslope footing
- 6 Downslope footing
- 7 Loose material
- 8 Soil backfill
- 9 Resultant of snow  
pressure

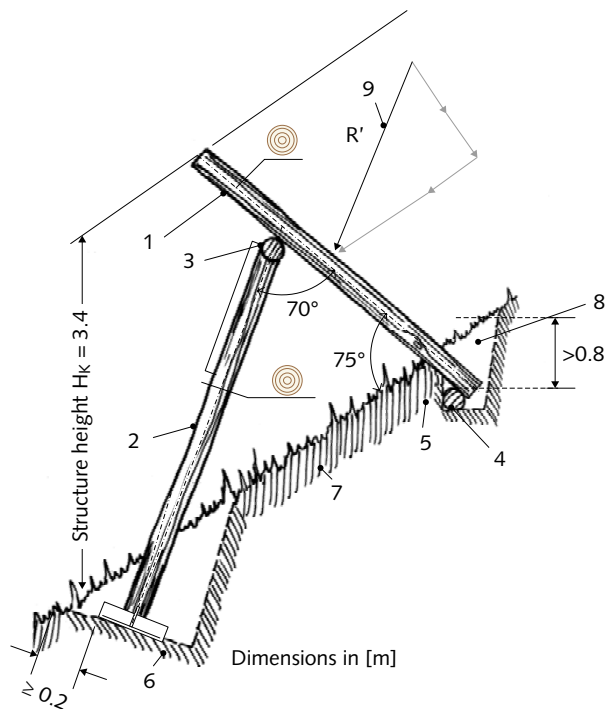

by a steel pin to a steel plate or concrete slab that is buried at least 20 cm deep in the in-situ soil. Wooden snow rakes are planned and positioned in the terrain in the same manner as permanent supporting structures. [34]

The distances in the fall line between individual structures depend particularly upon structure

height and slope inclination. With a slope inclination of  $35^\circ$  and structure height  $H_k$  of 3.4 m the distance between arrays of structures in the line of the slope is around 24 m. If distances are too large this can result in damage due to snow pressure. It is important that the uppermost structures are positioned directly below the highest point of the fracture line of avalanches. In open terrain with a relatively even relief it has proven expedient to position the structures in continuous lines (cf. Figure 51). When combined with afforestation and silvicultural measures, wooden snow rakes can be expected to have an effect similar to that of permanent supporting structures made of steel. The precondition to this is that timber quality meets the demands of the locally requisite service life, and that the young forest can assume the protective function after that period. In such cases, wooden snow rakes are an option that is relatively cost-effective and simple to erect.

Figure 51  
SLF-type wooden snow  
rake combined with  
afforestation to protect  
a transport route.



### 7.3.2 Measures to protect against gliding snow

Measures to protect against gliding snow are generally planned according to expert experience without verification of bearing capacity. Technical

construction guidance is available to planners. [37] The key measures are presented in the following.

#### 7.3.2.1 Stakes

Individual wooden stakes are driven into the soil manually or by machine, in groups of three (cf. Figure 52 and Figure 53). Distances in the fall line vary between 90 cm (45° slope inclination) and max. 2 m (30° slope inclination). The necessary stake diameters are 10 cm for roundwood and 16 cm for half-round stakes. Stake height above ground is 30–50 cm. The ideal ratio of driving depth to stake

length above ground is 2:1. The minimum driving depth is 60 cm in dense soils and 80–100 cm in loose soils. If driving depth is too small, the stakes can be pushed over and torn out by snow pressure. Stakes have proven their value not only to protect young plants, but also to prevent gliding snow movements on short, steep road embankments.

Figure 52  
Schematic of stake  
emplacement. Distances  
vary between 90 cm (45°)  
and 200 cm (30°),  
depending upon slope  
inclination.

- 1 Roundwood  
( $d = 10\text{--}15\text{ cm}$ ,  
 $L = 90\text{--}150\text{ cm}$ )
- 2 Half-round stake  
( $d = \text{min. } 16\text{ cm}$ ,  
 $L = 90\text{--}150\text{ cm}$ )

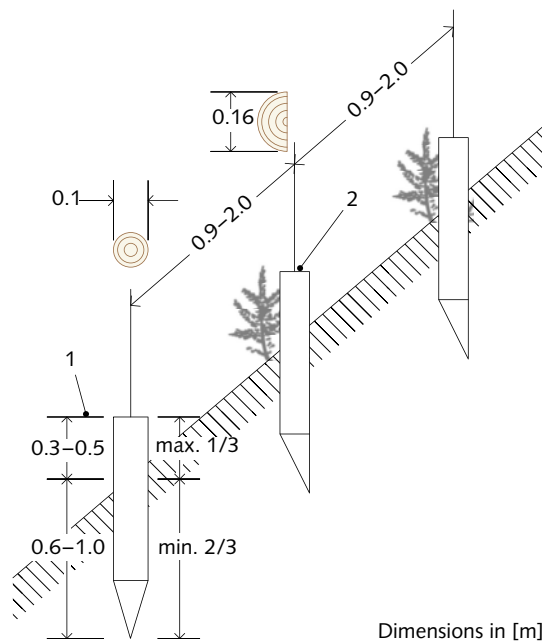

Figure 53  
Stakes to protect an access  
road against gliding snow;  
the stake driving ratio  
of 2:1 in/above ground  
is essential.



## 7.3.2.2 Tripods

The tripod, also known in Switzerland as 'Ogi-Bock', is the most frequently employed measure to control gliding snow in that country, with several tens of thousands such tripods countrywide. In afforestation contexts, these tripods not only protect young stands against gliding snow, but have also proven effective as protection against creeping snow for trees at the sapling and polewood ages. A further effect is that the area around the wooden poles becomes clear of snow earlier in the year. This extends the growing period for the young trees. A tripod consists of two roughly 2 m long roundwood beams with diameters of 10–14 cm that are crossed in a V-shape and has an upslope crossbeam that, depending upon soil conditions, is anchored with ground nails, piles or wire ropes. Downslope the roundwood beams rest on a supporting beam with a diameter of 12–15 cm that is footed on a small

concrete or steel ground plate (cf. Figure 54 and Figure 55). Tripods are positioned in a matrix with distances from supporting beam to supporting beam of 1.5–2.0 m. When they are to cover an entire area, 500–750 tripods are built per hectare, the precise number depending upon slope inclination. Tripods are about 1.5 m high. If the snowpack covers them entirely, the supporting beam can be pressed into the soil or the cantilevered parts of the roundwood beams can break. Tripods are ideally employed on slopes prone to gliding snow below the forest limit. Where slopes are flatter than roughly 35°, tripods can be positioned in groups in combination with afforestation. At the margins of groups it is important to position tripods carefully in order to prevent snow pressure damage as a result of edge effects.

Figure 54  
Schematic of tripods with pile anchor and sill anchor.

- A** Tripod with pile anchor  
**B** Tripod with sill anchor

- 1 Retaining beams: roundwood (d = 10–14 cm, L = 200 cm)
- 2 Support: roundwood (d = 12–15 cm, L = 220 cm)
- 3 Sill: roundwood (d = 16–20 cm, L = 200 cm)
- 4 Pile anchor: half-round (d = 16 cm, L = 80 cm)
- 5 Wire rope anchor (spiral d = 7,5 mm, galvanised)
- 6 Base plate: steel, stone or reinforced concrete (25/25/10)
- 7 Rock
- 8 Loose material (soil)

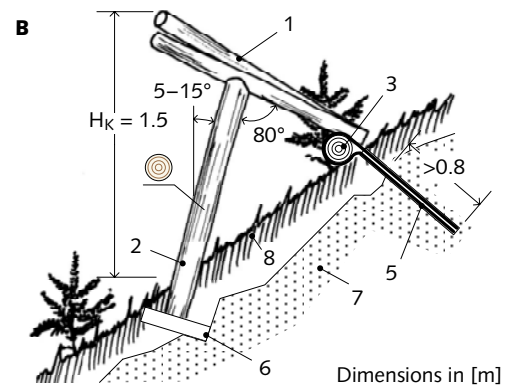
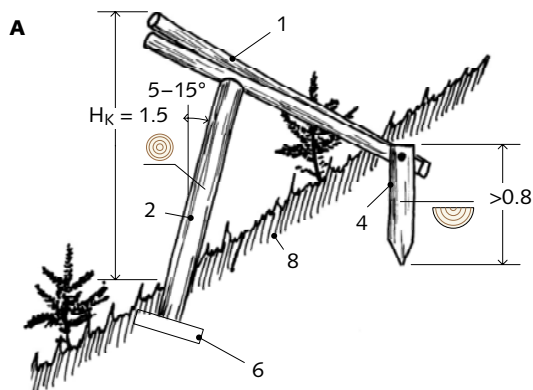

Figure 55  
Tripods with upslope sill protect young stands against gliding and creeping snow.



### 7.3.2.3 Anchored logs

A timber sill consists of a 4 m long roundwood beam with a diameter of 30 cm that is fixed by wire rope loops to the two wire rope anchors (cf. Figure 56 and Figure 57). The anchoring length in rock should be at least 0.8 m; in loose material around 3 m depending upon compactness. In loose material, toggle earth anchors rammed into the soil and expanded after ramming are sometimes employed instead of wire rope anchors; a further option is fixing the sills to steel shoes that have rod anchors. Sill distances in the fall line range between 3 m and 5 m depending upon slope inclination. Sills are installed individually in triangular groups. Ideal locations are exposed bedrock or shallow soils. In soils

with poor load-bearing capacity prone to erosion, the high costs of anchoring can make the installation of such sills uneconomic. Compared to tripods and stakes, timber sills are much more robust and can therefore also be used at high altitudes with great snow depths. Over time the sills can be pressed into the soil and thus lose effective height. This can be prevented by placing them on two 1.5 m long pieces of roundwood lying transverse to the slope, or by periodically digging them clear. In recent years timber sills have been deployed increasingly to protect ski runs against gliding snow avalanches.

Figure 56  
Schematic of anchored logs. Each log is anchored directly in the rock by means of two spiral wire ropes.

- 1 Transverse sill  
( $d = 30$  cm,  
 $L = 400$  cm)
- 2 Wire rope anchor  
(spiral  $d = 11$  mm,  
galvanised)
- 3 Anchor mortar
- 4 Rock
- 5 Loose material (soil)

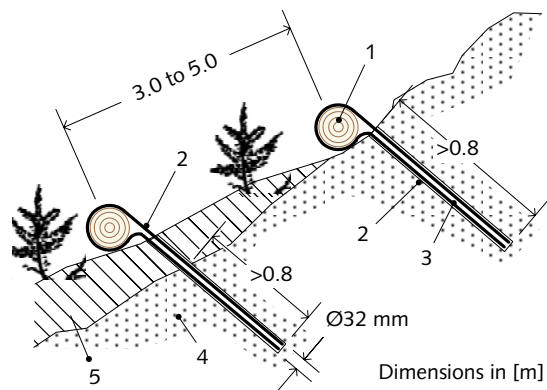
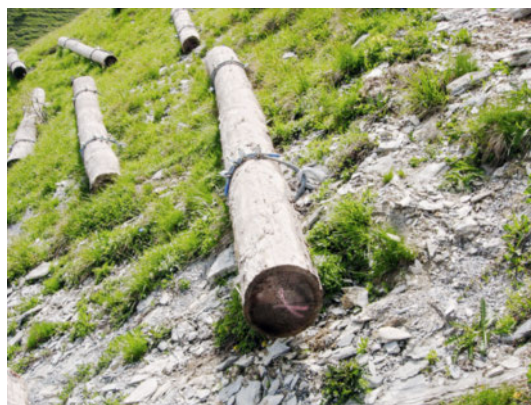

Figure 57  
Wooden logs anchored with two wire rope anchors. The advantage of wire rope anchoring is that the logs can be replaced more easily if required.



#### 7.4 Snowdrift fences

Over the past 20 years various snowdrift fences made of self-supporting, 5 m long timber elements have been employed successfully in the Swiss canton of Grisons (cf. Figure 59). This is a type of structure that was developed more than 50 years ago in the USA [61] and is used frequently there to protect main transport routes. The timber structure consists of three 4 m high beams inclined at an angle of 15°. Each beam has two supports and is screwed to two ground boards. 5 m long and 15 cm high boards are screwed to the beams at distances of 15 cm, so that the aspect of the fence is filled 50%. It is important to leave a bottom gap between the lowest board and the ground. The height of this gap should be at least 10% of fence height. The

bottom gap generates a local jet effect which prevents the fence from being snowed under early on. To provide lateral stability, three additional boards are fitted diagonally as wind bracing. The individual elements are anchored with six ground anchors. The advantage of this type of timber structure is that it can be built by one forest worker group and, if necessary, can be moved in the terrain with relative ease. The distance of the fence to an avalanche starting zone or to a transport route that is to be protected in this way should be 15 to 20 times the height of the fence (cf. Figure 58). A comprehensive analysis of the wind and snow conditions in the project area needs to be performed prior to construction. A level terrain is ideal.

Figure 58  
Schematic of a snowdrift fence designed to protect an avalanche defence structure against major snowdrift accumulation. The fence ensures that the snow masses are deposited above the structure. The distance  $L$  of the snowdrift fence to the area that is to be protected should be 15–20 times the height of the fence.

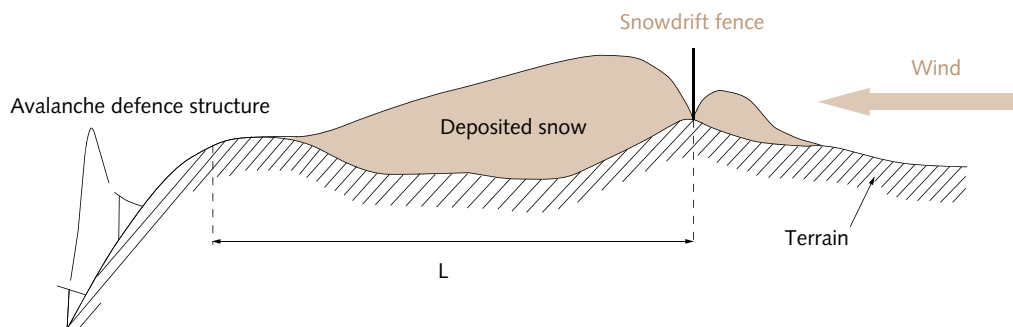

Figure 59  
Snowdrift fence made of timber elements. A large snow deposit has formed in the lee of the fence (to the left in the photo).



### 7.5 Limits to the use of wooden structures

The greatest drawbacks of wooden structures compared to steel are that they are less durable (cf. Figure 60) and less strong. Rot can cause premature failure of timber elements, particularly at the soil/air transition. The strength of wood permits cost-effective construction of temporary supporting structures up to a structure height of about 3.4 m. Greater heights would require excessively heavy building elements and overly massive sectional

dimensions. Temporary supporting structures such as wooden snow rakes make sense at sites where growth of new forest is possible. Where this is not possible within the service life of wooden structures, the use of steel structures can be more cost-effective, depending upon protection goal. Wooden snow rakes should therefore not be used where there is heavy snowfall, at sites with poor forest growing conditions, and particularly at sites above the forest limit. The foundation of wooden structures is generally carried out by means of drilled micropiles and anchors. Their use is therefore limited to soils with medium to good foundation conditions. Measures to protect against gliding snow such as tripods and stakes should only be applied below the forest limit, because under great snow depths they are more prone to damage than timber sills. On agriculturally utilised slopes prone to gliding snow, measures to control gliding snow are often not desired as they hamper agricultural management. All measures to control gliding snow only function if they are applied across an entire area.

Figure 60  
Broken rotten grate beam  
of a timber-steel snow  
bridge.



## 8 Protective structures and sustainability

This section places protective structures in the context of sustainability. It presents the calculations for a Life Cycle Assessment of a particular case study in Austria. It is important to note here that this example should not be taken as representative

of other built structures or building sites. Each structure is set in its own specific circumstances and is characterised by its own details during its erection, use and end-of-life phases, and must thus be assessed and calculated individually.

### 8.1 Introduction

The concept of sustainability was first defined in 1713 by Hans Carl von Carlowitz, a forester. He outlined the triad of ecological equilibrium, economic security and social equity. [62] His work, titled 'Sylvicultura Oeconomica', in which he called for the sustainable use of wood, was received well throughout Europe. Later, the principle of sustainability or sustainable use was extended beyond forest management and applied to numerous global environmental problems, becoming a maxim guiding action in all spheres of the economy and society. The now classic definition was put forward by the Brundtland Commission in 1987: 'Sustainable development is development that meets the needs of the present without compromising the ability of future generations to meet their own needs.' [63] Today, the prevalent understanding of 'sustainable development' is the one that emerged after the 1992 Rio Earth Summit (the United Nations Conference on Environment and Development, UNCED). This presents the concept in terms of three overlapping circles. Sustainable development thus aims at prudent resource use (environment, ecology), social solidarity (society) and economic well-being (economy). All three circles – ecology, society and economy – must be taken into account; they are interlinked and overlap substantially.

Based on this understanding, various methods have been developed to assess the sustainability of products and services and provide tools in support of sustainability decisions. One such method is Life Cycle Assessment (LCA). LCA can be applied to diverse systems ranging from specialised products to global, multinational corporations or even entire industries (SN EN ISO 14040 [64]). It primarily assesses ecological impacts. The social and economic aspects of sustainability are currently still addressed by separate but related methods – Social LCA (sLCA) and Life-Cycle Costing (LCC).

Switzerland's federal coordination centre for public authorities sponsoring construction and property-related work (Koordinationskonferenz der Bau- und Liegenschaftsorgane der öffentlichen Bauherren, KBOB) hosts a technical group for sustainable construction (Fachgruppe Nachhaltiges Bauen) which makes LCA reference data for building materials available to the construction sector. The values are based on sector-specific material and energy flows, whereby three environmental indicators are stated by way of simplification. These are: primary energy (distinguished according to renewable and non-renewable), greenhouse gas emissions (Treibhausgasemissionen, THG-E) and eco-points (Umweltbelastungspunkte, UBP). This calculation method takes account of product manufacturing, the transportation involved, and final demolition or disposal. It does not cover the use phase of building materials, i.e. the phase from erection/emplacement to replacement or demolition/dismantling. The values provided for wooden building materials are of limited utility for an LCA analysis of protective structures because they apply, in the case of wood, to sawn and dried timber. Those values thus capture processes that do not arise when erecting protective structures out of roundwood.

This section presents a case study in Austria. It compares the environmental impacts arising when wooden or concrete check dams are constructed in a mountain torrent catchment area in terms of two impact categories: greenhouse gas emissions (THG-E) [t CO<sub>2</sub>-eq.] and primary energy (PE) [GJ]. The focus is on ecological environmental impacts; the study addresses neither economic nor social impacts. [65]

## 8.2 Standards and datasets

The SN EN ISO 14040 [64] and SN EN ISO 14044 [66] standards provide guidance for the production and performance of LCAs. These standards set out the principles and frameworks of and requirements upon an LCA. An LCA covers the environmental aspects and potential environmental impacts throughout the life cycle of a product from resource extraction over production, use, waste treatment and recycling through to final disposal. [64]

Various software applications and datasets can be used to perform an LCA. The present case study used the OpenLCA software (Version 1.4.2) and the Swiss Ecoinvent database (Version 2.2, 2007 release, Switzerland). [67] The datasets generated in Switzerland were adjusted to the materials produced in Austria. Due to a lack of Austrian data for the fuel consumption and emissions of construction machines, these were determined using the Swiss Non-Road-Database [68] for the year 2015.

## 8.3 Life cycle assessment of torrent control structures – a case study

The selected case study examines torrent control structures in the Mauerbodenbach area, a sub-catchment of the Oselitzenbach stream in the district of Hermagor, Carinthia, Austria.

It analyses four check dams made of cast-in-situ concrete (see Figure 61), which serve to stabilise gullies and prevent slope slippage. The check dams analysed have fall heights of 2.5–4.5 m. Protection of the toe scour zones is provided by riprapping for which boulders were placed in cast-in-situ concrete. Five variants were calculated. Variant B1 captures the actual construction in concrete. Variant B2 assumes that transport distances are greater than they were for the actual construction project. The calculation of these two variants for concrete (B = Beton, the German for 'concrete') is based on the Mauerbodenbach 2006/07 construction report by the Austrian federal torrent and avalanche control agency (Wildbach- und Lawinenverbauung, WLV).

Variant H1 (H = Holz, the German for 'wood' or 'timber') calculates the structures, which were actually made of concrete, as if they had been made of wood, whereby the dimensions of the front view of the structures are taken to remain unaltered. Variant H2 assumes that transport distances are greater, and Variant H3 is based on the transport distances that would be realistic if regionally sourced timber were used. The calculation of the wood variants is based on the 2003 WLV execution report for control works on the Jagdhüttengraben, which is also located in the catchment of the Oselitzenbach (cf. Figure 62). These control works used robinia timber from Romania. Protection of the toe scour zones was provided by riprapping for which boulders were placed in ready-mixed concrete.

Figure 61 (left)  
Concrete check dams  
on the Mauerbodenbach  
constructed in 2006/2007  
[65].



Figure 62 (right)  
Wooden check dams  
on the Jagdhüttengraben  
constructed in 2003 [65].



The following Table 4 lists a selection of the main construction materials and equipment relevant to the case study. Such a compilation is termed 'inventory' in the LCA terminology of SN EN ISO 14040. [64]

Table 4  
Excerpt from the inventory analysis [65].

Material/machine	Unit	Concrete variants (B1, B2)	Wood variants (H1, H2, H3)
Hard concrete (heavy)	t	1.38	–
Cement CEM II/32.5 N in bulk (Portland)	t	262.38	–
Broken concrete 0/22	t	1,512.62	–
Rubble	t	–	1,254.60
Crushed stone	t	62.40	62.40
Reinforcement steel	t	8.64	–
Roundwood MDM > 24	m <sup>3</sup>	5.87	178.87
Reinforcing steel nails	kg	24.80	1,114.8
Truck + crane	h	100.50	155.50
Crawler excavator	h	312.50	293.00
Walking excavator	h	4.50	441.50
Crawler dumper	h	216.00	–
VW Golf	h	26.00	26.00

Table 5 provides an excerpt from the transportation of all materials, listing the distances for the two cast-in-situ concrete variants (B1, B2) and the three wooden variants (H1, H2, H3). For the concrete variants, the average truck transport distance is 66 km (B1) and 135 km (B2), respectively. For the wooden variants, the average truck transport distance is 54 km (H1), 114 km (H2) and 45 km (H3).

Table 5 Case study variation by transport distances – excerpt [65].

Material transported	Means of transport	Concrete check dam variants		Wooden check dam variants		
		B1 actual transport distances [km]	B2 extended transport distances [km]	H1 actual transport distances [km]	H2 extended transport distances [km]	H3 Transport distances if regionally sourced timber is used [km]
Cement	Truck	138	200	–	–	–
Crushed stone	Truck	32	100	32	100	32
Rubble	Truck	–	–	18	100	18
Reinforcement steel	Truck	130	300	130	300	130
Roundwood – Larch	Truck	28	100	–	–	28
Roundwood – Robinia	Truck	–	–	69	100	–
Roundwood – Robinia	Train	–	–	500	1500	–
Incidentals	Pickup	69	100	69	100	69
Walking excavator	Truck	38	100	38	100	38
Dumper	Truck	69	100	–	–	–
Mixer IMPE 500lt	Truck	69	100	–	–	–
Cement conveyor screws	Truck	69	100	–	–	–
Cement balances	Truck	69	100	–	–	–
Containers	Truck	69	100	69	100	69

The anticipated service lives and maintenance and repair costs were adopted from the Austrian directive on the cost-effectiveness analysis and prioritisation of torrent and avalanche control works (Richtlinie 'Wirtschaftlichkeitsuntersuchung und Priorisierung von Massnahmen der Wildbach- und Lawinerverbauung'). [69] The directive assumes that reinforced-concrete structures have a service life of 80 years and annual maintenance amounting to 0.2 % of production costs. For the purposes of the present LCA study, this maintenance rate was taken as an annual percentage of the energy input required for construction of a specific structure or as an annual percentage of the emissions attribut-

able to it. The directive ascribes to timber structures a service life of 40 years and a maintenance rate of 0.5 %. It ascribes to the riprapping needed to protect against scouring at the toe of check dams a service life of 40 years and an annual maintenance rate of 1 % of the production costs. If the protective function of a structure is still required after its service life, defined in this manner, has ended, then it is constructed anew (usually simply next to the old structure in order to save the cost of demolition). If the protective function of a structure is no longer required, then in Austria it is usually simply left in the landscape; this is termed 'landfill' (Deponie).

## 8.4 Findings

With regard to energy input, the findings for the construction phase show for the real variants B1 and H1 that the production of cast-in-situ concrete determines the concrete variant B1 (cf. Figure 63), while transportation to and machine use at the building site play a major role for the wooden variant H1. Total primary energy input is 1935 GJ for

the concrete check dams and 990 GJ for the wooden check dams. Total energy input for construction of the concrete structures is thus roughly twice that of the wooden structures. Compared to Variant H1, the use of regionally sourced timber (Variant H3) delivers an improvement in energy input by 11 %.

Figure 63  
Energy input of construction phase for executed variants B1 (concrete, actual transport distances) and H1 (wooden, actual transport distances) and of variants with extended transport distances (B2 and H2) and a variant with shorter transport distances due to use of regionally sourced timber (H3) [65].

- Machine use
- Transportation to building site
- Production of building materials

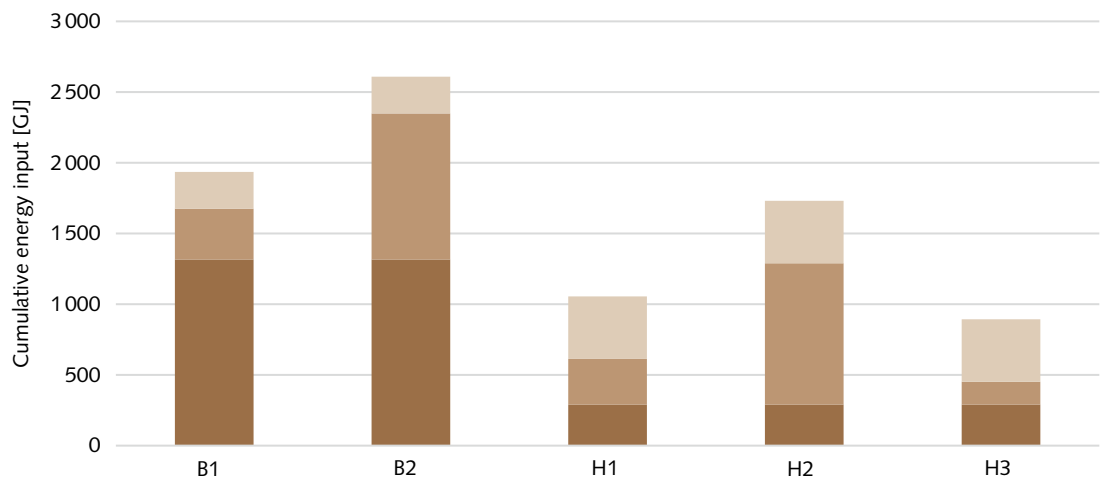

With regard to greenhouse gases, the findings for the construction phase show for the real variants B1 and H1 (cf. Figure 64) that the production of cast-in-situ concrete determines the results for the concrete check dam. Transportation to and machine use at the building site play a much greater role for the wooden variant. The total greenhouse gas emissions attributable to the concrete structures amount to 278 t CO<sub>2</sub>-eq.; those attributable to the wooden structures are 87 t CO<sub>2</sub>-eq. In contrast to the primary energy findings, the equivalent greenhouse gas emissions of the concrete structures are thus about three times greater than those

of the wooden structures. However, if we consider machine use at the building site in isolation, the emissions attributable to construction of the wooden structures are 12 t CO<sub>2</sub>-eq. higher than those attributable to construction of the concrete structures. The impact of transport distances upon greenhouse gas emissions is revealed by consideration of variants B2 (17 % higher emissions than B1) and H2 (56 % higher than H1). This shows that the level of greenhouse gas emissions depends substantially upon the distances over which building materials are transported to the building site.



Figure 64  
Greenhouse gas emissions of construction phase for executed variants B1 (concrete, actual transport distances) and H1 (wooden, actual transport distances) and of variants with extended transport distances (B2 and H2) and a variant with shorter transport distances due to use of regionally sourced timber (H3) [65].

- Machine use
- Transportation to building site
- Production of building materials

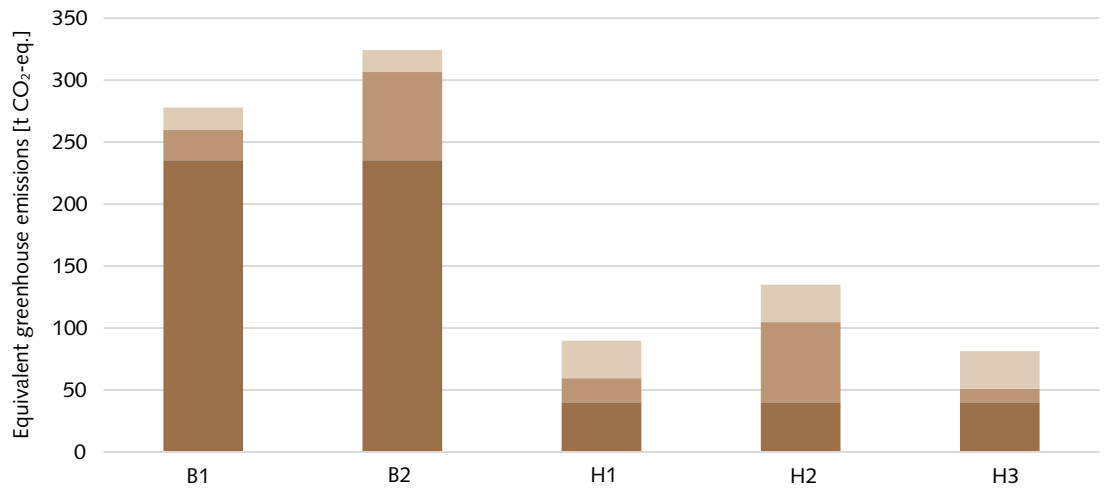

Compared to Variant B1, Variant H1 saves 945 GJ energy input in the construction phase. If the entire life cycle is considered (over a period of 80 years, with maintenance work (concrete) or new construction (timber) after 40 years and landfill after 80 years), in which the cribwalls should be replaced completely once, the two variants exhibit roughly

the same energy input (cf. Figure 65). Variant H2 is the only wooden variant which, due to the longer transport distances, requires a greater energy input over 80 years than the concrete variant with extended transport distances (B2), namely by 436 GJ. This underscores once more the impact of transport distances for building materials.

Figure 65  
Energy input over 80 years for concrete and wooden variants B1 and H1 (actual transport distances) and of variants B2 and H2 (extended transport distances) and variant H3 (shorter transport distances due to use of regionally sourced timber) [65].

- Variant B1
- Variant H1
- Variant B2
- Variant H2
- Variant H3

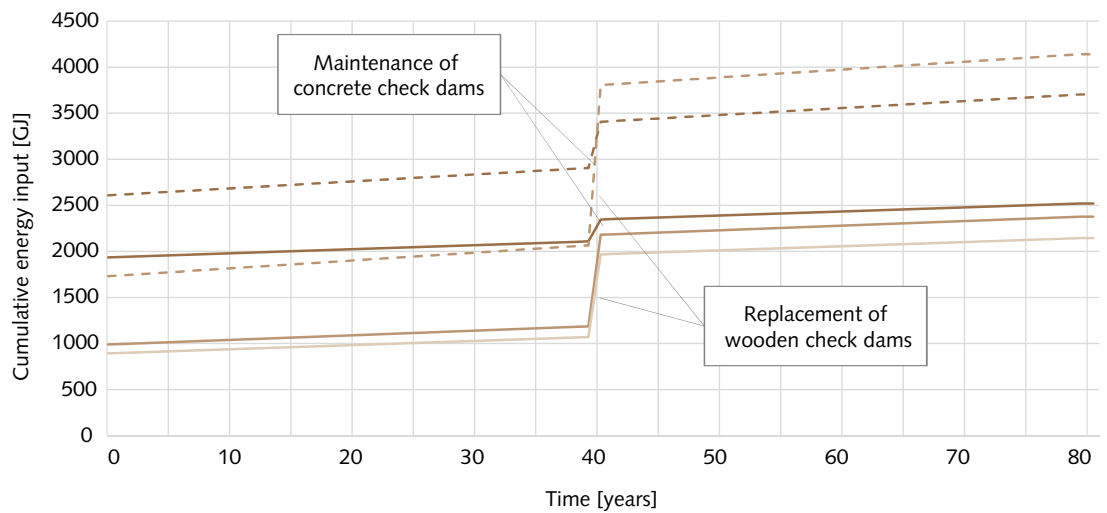

After erecting the structures, there is a difference of 192 t CO<sub>2</sub>-eq. equivalent greenhouse gas emissions in favour of the wooden variant when comparing variants B1 and H1. After a period of 80 years, this difference is reduced to 135 t CO<sub>2</sub>-eq. (cf. Figure 66). In a similar comparison between

variants B2 and H2, the difference is reduced after 80 years from 189 t CO<sub>2</sub>-eq. to 102 t CO<sub>2</sub>-eq. Under the assumptions made, the emissions benefit of wooden structures compared to concrete structures halves over the life cycle.

Figure 66  
Greenhouse gas emissions over 80 years for concrete and wooden variants B1 and H1 (actual transport distances) and of variants B2 and H2 (extended transport distances) and variant H3 (shorter transport distances due to use of regionally sourced timber) [65].

— Variant B1  
— Variant H1  
- - Variant B2  
- - Variant H2  
— Variant H3

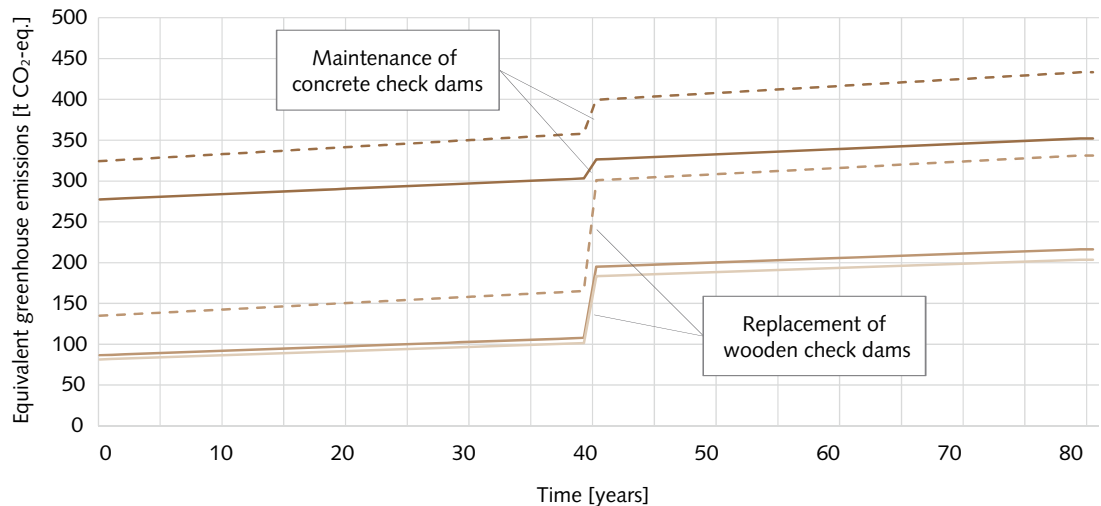

## 8.5 Conclusions

The case study shows that wooden structures generally have a smaller environmental 'footprint' than concrete structures. Comparison of the variants reveals that in the construction phase the LCA outcome of wooden structures is better than that of concrete structures. On the other hand, if the entire life cycle of structures is considered and if extended transport distances are assumed, the primary energy outcome of concrete structures is better than that of wooden structures. It is important to note here that the service life of wooden structures is assumed to be 40 years (although, as this documentation shows, under favourable conditions substantially longer service lives are possible) and that the calculations are based on the assumption that the concrete structures are not demolished when they have reached the end of their lives. With regard to greenhouse gas emissions, wooden structures have a better LCA outcome across the entire life cycle, even if extended transport distances are assumed.

It is therefore recommendable when constructing protective structures out of roundwood to focus on the regionality of building materials and the associated shorter transport distances. Durable timber

species suited for protective structures, such as sweet chestnut and larch, also grow in Switzerland's forests. LCA studies are a tool allowing quantification of differences in environmental impact. Based upon their outcomes, the construction site processes, modes of operation and deployment of materials and machines can be optimised regardless of the building material selected.

When protective structure erection is linked with soil bioengineering constructions, LCA outcomes can be improved further. This is because using regional or site-appropriate planting material is beneficial in all cases, and also because the vegetation, a living building material, sequesters CO<sub>2</sub> during the use phase and thus has a positive influence upon the overall outcome. [70] [71]

Aesthetics are a further argument for using timber or living plant material. A structure made of natural and site-appropriate materials integrates better into the landscape; in some cases it becomes no longer perceptible as a built structure at all within a few years. Concrete structures, in contrast, will always remain apparent as alien, artificial elements in nature.

LCA is a governance tool for decisions on planning and executing protective structures that can be deployed to minimise overall environmental impacts.

It is excellently suited to making active contributions to the implementation of climate change adaptation strategies.

Figure 67  
Check dam in the  
Schaferabach stream  
in the municipality of  
Plaffeien, Switzerland.  
Some of the dams in  
the Schaferabach are  
known to have been built  
between 1940 and 1945.  
This means they have  
served unaltered for more  
than 75 years.

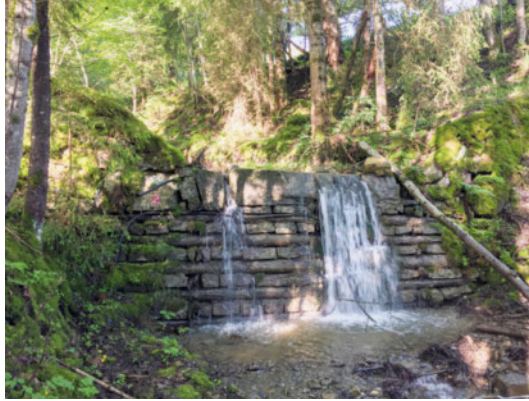

## 9 Overall conclusions

The following comments assemble arguments that have partly already been mentioned in the chapters above. They are of general nature and are not nec-

essarily applicable to every situation. The advantages and drawbacks of using timber need to be analysed in depth for each individual case.

### 9.1 Advantages of using timber for protective structures

In environmental terms wood, and particularly roundwood, is a natural product which should be associated directly with sustainable forest management. Its growth produces oxygen through photosynthesis and fixes CO<sub>2</sub>; later the wood is decomposed again in a natural cycle. The effect of roundwood used as building material upon greenhouse gas levels in the atmosphere is therefore positive over the short term thanks to the storage of CO<sub>2</sub> in wood in built structures, and largely neutral over the longer term (assuming that local resources are used).

If locally sourced material is used, the processing, storage, transportation and building processes associated with a structure made of wood involve substantially lower energy input and emissions compared to other building materials.

If wood is untreated, environmental risks arising from impurities and toxic substances are non-existent compared to other building materials. Moreover, the introduction of additional building materials can be largely dispensed with, with the exception of fastenings made of metal (screws, nails, plates etc.). These points are highly relevant and should always be taken into account with a view to dismantling at the end of the structures' service lives and avoiding the entry into nature of toxic and waste substances.

The favourable environmental and aesthetic aspects, such as the integration of structures into the landscape, can reduce resistance among the wider public and environmental groups in permitting procedures.

In economic terms unprocessed longwood is highly cost-effective, particularly when it is used close to the site of felling. Locally and expertly employed, its use delivers cost-effective solutions. In most cases there is no need for later demolition; this further reduces costs.

Building site logistics are usually simpler; especially in impassable terrain wood can be the optimal building material.

Building structures to protect against natural hazards is largely a task of the public sector. Local authorities, and also cooperatives, are thus often directly involved as sponsors of projects. These sponsors are often forest owners, which can put them in a position to supply the wood themselves as an input rendered for their own account.

In social terms, value creation takes place to a greater degree at the local and regional levels if construction projects use wood. The deployment of local construction teams or forest worker groups, and of staff of the sponsors themselves, can nurture and boost local know-how and, not least, the population's awareness of the existence of natural hazards and protective structures. This can facilitate risk prevention, e.g. at the local planning level.

Figure 68  
Trees felled transverse to the slope: a simple method to protect against rockfall.



In technical terms wood is ideally employed wherever the function of a structure can be adopted by the growing vegetation after it has decomposed. This is typically the case for avalanche or gliding snow control/mitigation structures below the forest limit, and for landslide and erosion control structures. Covered wood can increase soil moisture and quality and thus promote vegetation development and root formation. It is also conceivable that for other reasons a limited service life is accepted or, in special cases, even intended.

The relatively low specific weight of wood (2–4 times less than soil material or concrete and blocks) facilitates transport and makes its use particularly suitable where the subgrade is poor or prone to sliding. Timber structures tend to be flexible and elastic; slow slope deformation and subsidence do not lead immediately to structural failure.

Wood is very simple to work, the dimensions of individual elements can be adjusted continuously to the ongoing situation during the construction process.

In the planning process, generally simplified requirements apply to necessary designed and calculated dimensions. In many cases superdimensioning can be relied upon from the outset because there is no need to save building material, account must be taken of changes in wood properties during ageing and empirical values can be used.

In terms of maintenance work, it can be said that, if wood use is planned well and construction work carried out properly, the above-mentioned advantages also apply. However, in comparison to building materials such as steel or concrete a slightly greater inspection and maintenance effort should be accepted and provided for.

Relevant maintenance issues can arise mainly for torrent check dams because in this field replacing individual elements can be difficult or too costly. Maintenance work on such structures should therefore concentrate on individual problematic points that can be remedied relatively easily. Provision may then need to be made for replacement of the structures at the end of their service life and utilisation period.

Landslide and erosion control structures combined with bioengineering largely need no maintenance work. Moreover, later forest and vegetation management activities are simpler.

Maintenance requirements for bed protection of water drainage channels (and fascines) are low in principle thanks to the wet state of the wood.

For avalanche and gliding snow control structures maintenance is limited to inspection and the replacement of individual elements or structures after winters with heavy snowfall.

In most cases no demolition or dismantling is required at the end of the service life.

Figure 69 (left) and Figure 70 (right) Cribwalls stabilise vegetated slopes and merge into the landscape.

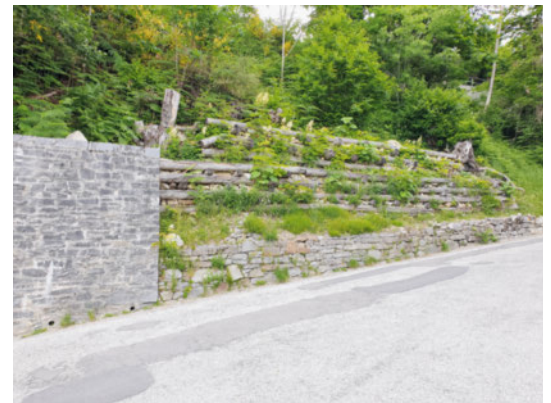

## 9.2 Drawbacks of using timber for protective structures

Precisely because wood is a natural building material with a nutrient cycle determined by nature, the greatest drawback by far is the limited service life of wooden protective structures outdoors and the decline over time of strength and load-bearing capacity due to the material's natural decomposition. As the present publication sets out, the service life and utilisation period of protective structures made of wood is highly variable. Depending upon the circumstances, their functional utility can already be compromised after a minimum of ten years, while in other cases service lives can be as long as 100 years. The proper planning and execution of such works plays a key role in this regard.

Because of its heterogeneity and limited service life timber sometimes has a difficult status in natural hazard management. Empirical approaches based on expert experience are often taken when dimensioning protective structures made of roundwood. As a result, planners have been, and continue to be, uncertain about how to handle this building material. How can requisite verifications of load-bearing safety and functional utility be furnished? How should the uncertainties attaching to timber use be

handled? Interesting research, publications and projects serving to improve acceptance for the use of timber in protective structures have improved this situation over the past 20 years (see on this also Chapter 3 of the present publication).

Even with building materials such as reinforced concrete or masonry it is not always easy to handle such uncertainties. All kinds of examples demonstrate clearly that we do not build for eternity. To name but a few: the disaster in Gondo in the Swiss canton of Valais following the failure of a retaining wall; check dams on torrents made of concrete that have been undercut or destroyed; the demolition of earlier canalisation works and training walls on valley rivers following the paradigm shift in hydraulic engineering; the need to replace permanent avalanche control structures because of foundation (permafrost) problems. Furthermore, changes in process dynamics or, not least, risk management approaches (e.g. stronger risk reduction focus on the damage potential side, or adjustments to protection goals) can substantially alter the required service lives and utilisation periods of structures designed to protect against natural hazards.

Figure 71 (left)  
Full coverage can greatly extend service life even if less durable timber species, such as spruce, are used.



Figure 72 (right)  
Using durable timber species such as sweet chestnut is a further way to extend the service life of retaining structures.



### 9.3 Weighing the pros and cons of timber use

Detailed information on this important aspect is provided in the various chapters of this publication, especially in the sections titled 'Limits to the use of wooden structures'. Despite the many advantages offered by timber as building material there can be good reasons for choosing other types of construction. When planning a specific project this choice should be made following careful weighing of the pros and cons. The following questions can guide such deliberations.

- Are one or several advantages (mainly environmental or economic) of using timber relevant to the present case?

- Does a wooden structure fit well in its surroundings?
- Are a limited service life and possibly necessary later replacement acceptable?
- Is it acceptable that the structure loses load-bearing capacity over time?
- Can the vegetation assume the stabilising effect over the medium and long term?
- Are the risks in the case of failure of the structure limited or, respectively, acceptable?

If these questions can largely be answered in the positive the choice of timber is well founded.

Figure 73 (left)  
Wooden crib to protect an embankment against erosion, using wood wool and willow cuttings.



Figure 74 (right)  
Tripods and a rockfall protection wall made of wood safeguard infrastructure.



## 10 Partners



**Caprez Ingenieure AG**  
Via vers Mulins 19  
7513 Silvaplana  
Tel. +41 81 838 77 00  
www.caprez-ing.ch  
silvaplana@caprez-ing.ch

Caprez Ingenieure AG is an engineering consultancy founded in 1963. Today it has 16 units located between Zurich and St. Moritz. Each unit operates independently and is closely networked at local level. The overall company profits from the ongoing transfer of knowledge among the units – not least in forest management, environmental engineering and natural hazard control.



**Castagnostyle Sagl**  
Al Dosso  
6807 Taverner  
Tel. +41 79 132 31 30  
verkauf@castagnostyle.ch  
www.castagnostyle.ch

Castagnostyle is the meeting point of chestnut wood professionals. We deliver services in all relevant fields – wood trade, woodcutting, control structures and playing grounds made of timber, nature conservation work etc. The company is part of a group of forestry enterprises and is located in Switzerland's best chestnut-growing regions. We employ wood professionals and train foresters.



**fim**  
Bruno Brunner  
Glütschbachstrasse 3  
3661 Uetendorf  
Tel. +41 33 345 04 75  
info@fim-uetendorf.ch  
www.fim-uetendorf.ch

fim is a major supplier of equipment for the forest management sector. It stocks extensive ranges of Caravaggi, Maxwald and AMR products. It also maintains a spacious Stihl Shop in which the entire product range of that maker can be taken to hand.



**Forst Aletsch**  
Alt Chirchwäg 59  
3984 Fieschertal  
Tel. +41 27 971 30 07  
info@forstaletsch.ch  
www.forstaletsch.ch

We ensure that our forests are in a good state and that their functions are maintained in the long term. Some 90 % of the forests we manage are protection forests, protecting people, fauna and material assets against natural hazards. Our forests are also the resource base for wood energy and roundwood products. Most of our wood goes to sawmills and the wood processing industry. We process a part of it ourselves to practical things such as tables and benches or flower and fountain troughs. We also make individual pieces of playground equipment and erect entire, large playgrounds and outdoor high-rope climbing parks.



**Lindner Suisse GmbH**  
Bleikenstrasse 98  
9630 Wattwil  
Tel. +41 71 987 61 51  
holzwohle@lindner.ch  
www.lindner.ch

Since 1920, Lindner Suisse GmbH develops and produces wood wool specialty products made from healthy, certified Swiss timber according to prescription and according to the Swiss wood wool standard: for infrastructure, horticulture, landscaping, hydraulic engineering, erosion control, drainage and animal hygiene, and as kindling aid and packaging material. Lindner Suisse also produces high-grade filling material chips and is a point of contact for requirements-driven packaging solutions.



## 11 References

- [1] Andres, N., Badoux, A. (2019): Unwetterschäden in der Schweiz im Jahre 2018. *Wasser Energie Luft*, 111. Jahrgang, Heft 1, pp. 29–38
- [2] PLANAT (2004): Sicherheit vor Naturgefahren – Vision und Strategie. PLANAT Reihe 1/2004, p. 40
- [3] Margreth, S., Schweizer, J. (2018): Coaz – Pionier der schweizerischen Lawinenforschung. *Bündner Wald* 71: pp. 72–79
- [4] Brändli, U.-B., Abegg, M., Allgaier Leuch, B. (2020): Schweizerisches Landesforstinventar. Ergebnisse der vierten Erhebung 2009–2017. Birmensdorf, Eidgenössische Forschungsanstalt für Wald, Schnee und Landschaft WSL, Bundesamt für Umwelt, Bern
- [5] Losey, S., Wehrli, A. (2013): Schutzwald in der Schweiz. Vom Projekt SilvaProtect-CH zum harmonisierten Schutzwald. Bundesamt für Umwelt BAFU, Bern, p. 29
- [6] Thali, U. (2006): Schutzwirkung des Waldes anhand des Felssturz-Ereignisses «Wilerwald», Gurtnellen, vom 31. Mai 2006. Altdorf: Kanton Uri, Bericht Schweiz Nationalstrassen N2, p. 21
- [7] Olmedo, I., Bourrier, F., Bertrand, D., Berger, F., Limam, A. (2018): Dynamic analysis of wooden rockfall protection structures subjected to impact loading using a discrete element model. *Eur. J. Environ. Civil Eng.* 24, pp. 1430–1449
- [8] Ringenbach, A., Stihl, E., Bühler, Y., Bebi, P., Bartelt, P., Rigling, A., Christen, M., Lu, G., Stoffel, A., Kistler, M., Degonda, S., Simmler, K., Mader, D., Caviezel, A. (2021): Full scale experiments to examine the role of deadwood on rockfall dynamics in forests. *Nat. Hazards Earth Syst. Sci. Discuss.* [preprint], <https://doi.org/10.5194/nhess-2021-319>, in review, 2021
- [9] Ammann, M. (2006): Schutzwirkung abgestorbener Bäume gegen Naturgefahren. ETH Diss. Nr. 16638, p. 190
- [10] Dorren, L., Berger, F., Frehner, M., Huber, M., Kühne, K., Métral, R., Sandri, A., Schwitter, R., Thormann, J., Wasser, B. (2015): Das neue nais-Anforderungsprofil Steinschlag. *Schweizerische Zeitschrift für Forstwesen* 166 (1), pp. 16–23
- [11] Bigot, C. (2014): Cinématique de décomposition et rôle de protection pare-pierres du bois mort: le cas des rémanents. Diss. Université de Grenoble, p. 216
- [12] Hararuk, O., Kurz, W.A., Didion, M. (2020): Dynamics of dead wood decay in Swiss forests. *For. Ecosyst.* 7, p. 36
- [13] Begemann, W., Schliechtl, H.M. (1986): *Ingenieurbilogie. Handbuch zum naturnahen Wasser- und Erdbau.* Bauverlag, p. 216
- [14] Moos, C., Bebi, P., Schwarz, M., Stoffel, M., Sudmeier-Rieux, K., Dorren, L. (2018): Ecosystem-based disaster risk reduction in mountains. *Earth-Science Reviews* 177, pp. 497–513
- [15] Böll, A., Gerber W., Graf F., Rickli, C. (1999): Holzkonstruktionen im Wildbach-, Hang- und Runsenverbau. Birmensdorf, Eidgenössische Forschungsanstalt für Wald, Schnee und Landschaft
- [16] Norm SN EN 335 (2013): Dauerhaftigkeit von Holz und Holzprodukten – Gebrauchsklassen: Definitionen, Anwendung bei Vollholz und Holzprodukten. Schweizerischer Ingenieur- und Architektenverein, Zurich
- [17] Lignum (2021): *Holzbautabellen 1 – Handbuch für die Bemessung*, Zurich
- [18] Butin, H. (1983): *Krankheiten der Wald- und Parkbäume. Leitfaden zum Bestimmen von Baumkrankheiten.* Georg Thieme Verlag, New York
- [19] Bosshard, H.H. (1984): *Holzkunde. Band 3: Zur Biologie, Physik und Chemie des Holzes.* 2. Aufl., Birkhäuser Verlag
- [20] Florineth, F. (2014): Langjährige Hangsicherung durch bepflanzte Holzkrainerwände in Südtirol. *Ingenieurbilogie* 3/14
- [21] Meierhofer, U.A., Zumoberhaus, M. (1992): *Holzkonstruktionen im Wanderwegbau. Band 153, BUWAL*
- [22] Nötzli, K. (2002): Ursachen und Dynamik von Fäulen an Holzkonstruktionen im Wildbachverbau. Dissertation der Eidgenössischen Technischen Hochschule Zürich Nr. 14974
- [23] Norm SN EN 350 (2016): Dauerhaftigkeit von Holz und Holzprodukten. Schweizerischer Ingenieur- und Architektenverein, Zurich
- [24] Findlay, W.P.K. (1962): *The preservation of timber.* Adam & Charles Black, London
- [25] Lignum (2021): Lignatec 33, Verklebte Laubholzprodukte für den statischen Einsatz, Zurich
- [26] Nötzli, K., Böll, A., Graf, F., Sieber, T.N., Holdenrieder, O. (2008): Influence of decay fungi, construction characteristics, and environmental conditions on the quality of wooden check-dams. *Forest Products Journal*, 58 (4), pp. 72–79
- [27] Rickli, C., Graf, F. (2014): Wildbachsperren aus Fichte und Tanne: Festigkeit und Pilzbefall in den ersten Jahren. *Schweizerische Zeitschrift für Forstwesen*, 165 (4), pp. 79–86
- [28] Norm SIA 267 (2013): *Geotechnik.* Schweizerischer Ingenieur- und Architektenverein, Zurich
- [29] Norm SIA 260 (2013): *Grundlagen der Projektierung von Tragwerken.* Schweizerischer Ingenieur- und Architektenverein, Zurich
- [30] Norm SIA 261 (2020): *Einwirkungen auf Tragwerke.* Schweizerischer Ingenieur- und Architektenverein, Zurich
- [31] Norm SIA 261/1 (2020): *Einwirkungen auf Tragwerke – Ergänzende Festlegungen.* Schweizerischer Ingenieur- und Architektenverein, Zurich
- [32] Böll, A. (1997): *Wildbach- und Hangverbau. Berichte der Eidgenössischen Forschungsanstalt für Wald, Schnee und Landschaft, Nr. 343*
- [33] Technische Regel ONR 24801 (2013): *Schutzbauwerke der Wildbachverbauung – Statische und dynamische Einwirkungen; Austrian Standards International – Standardisierung und Innovation.* Wien
- [34] Margreth, S. (2007): *Lawinenverbau im Anbruchgebiet. Technische Richtlinie als Vollzugshilfe. Umwelt-Vollzug Nr. 0704.* Bundesamt für Umwelt, Bern, WSL Eidgenössisches Institut für Schnee- und Lawinenforschung SLF, Davos
- [35] Technische Regel ONR 24805 (2010): *Permanenter technischer Lawinenschutz – Benennungen und Definitionen sowie statische und dynamische Einwirkungen.* Austrian Standards International, Wien
- [36] Technische Regel ONR 24806 (2011): *Permanenter technischer Lawinenschutz – Bemessung und konstruktive Ausgestaltung.* Austrian Standards International, Wien
- [37] Leuenberger, Franz (2003): *Bauanleitung Gleitschneeschutz und temporärer Stützverbau.* Eidgenössisches Institut für Schnee- und Lawinenforschung SLF, Davos
- [38] Norm SIA 265 (2021): *Holzbau.* Schweizerischer Ingenieur- und Architektenverein, Zurich
- [39] Norm SIA 265/1 (2018): *Holzbau – Ergänzende Festlegungen.* Schweizerischer Ingenieur- und Architektenverein, Zurich
- [40] Technische Regel ONR 24802 (2011): *Schutzbauwerke der Wildbachverbauung – Projektierung, Bemessung und konstruktive Durchbildung.* Austrian Standards International, Wien
- [41] Norm SIA 263 (2003): *Stahlbau.* Schweizerischer Ingenieur- und Architektenverein, Zurich
- [42] Fernández-Raga, M., Palencia, C., Keesstra, S., Jordán, A., Fraile, R., Angulo-Martínez, M., Cerdà, A. (2017): Splash erosion. A review with unanswered questions. *Earth-Science Reviews*, 171, pp. 463–477
- [43] Ziegler, A.D., Sutherland, R.A., Giambelluca, T.W. (2000): Partitioning total erosion on unpaved roads into splash and hydraulic components: The roles of interstorm surface preparation and dynamic erodibility. *Water Resources Research*, 36 (9), 2787–27

- [44] Bernatek-Jakiel, A., Poesen, J. (2018): Subsurface erosion by soil piping: significance and research needs. *Earth-Science Reviews*, 185, Oct. 2018, pp. 1107–1128
- [45] Schwarz, M., Poesen, J., Rey, F., Holbling, D., Phillips, C. (2020): Bio-physical performance of erosion and sediment control/mitigation techniques – an international comparison to common practices in New Zealand. LC3891
- [46] Lifa, I. (2014): Entwicklung und Anwendung von naturbelassener Holzwolle für die Hangsicherung. *Ingenieurbiologie* 3/14
- [47] Zeller, J., Trümpfer, J. (1984): Rutschungsentwässerung. Birmensdorf, Eidgenössische Forschungsanstalt für Wald, Schnee und Landschaft
- [48] Cislaghi, A., Cohen, D., Gasser, E., Bischetti, G. B., Schwarz, M. (2019): Field measurements of passive earth forces in steep, shallow, landslide-prone areas. *Journal of Geophysical Research: Earth Surface*, 124, pp. 838–866. <https://doi.org/10.1029/2017JF>
- [49] Gray, D.H., Sotir, R.B. (1996): *Biotechnical and soil bio-engineering slope stabilization: a practical guide for erosion control*. John Wiley & Sons
- [50] Schwarz, M., Giadrossich, F., Cohen, D. (2013): Modeling root reinforcement using a root-failure Weibull survival function. *Hydrol. Earth Syst. Sci.*, 17, pp. 4367–4377
- [51] Schwarz, M., Rist, A., Cohen, D., Giadrossich, F., Egorov, P., Büttner, D., Stolz, M., Thormann, J.-J. (2015): Root reinforcement of soils under compression. *J. Geophys. Res. Earth Surf.*, 120, pp. 2103–2120, doi:10.1002/2015JF003632
- [52] Florin, F. (2004): *Pflanzen statt Beton. Handbuch zur Ingenieurbiologie und Vegetationstechnik*. Berlin/Hannover, Patzer Verlag
- [53] Flepp, G., Robyr, R., Scotti, R., Giadrossich, F., Conedera, M., Vacchiano, G., Fischer, C., Ammann, P., May, D., Schwarz, M. (2021): Temporal Dynamics of Root Reinforcement in European Spruce Forests. *Forests* 12 (6):815, <https://doi.org/10.3390/f12060815>
- [54] Bischetti, G. B., De Cesare, G., Mickovski, S. B., Rauch, H. P., Schwarz, M., Stangl, R. (2021): Design and temporal issues in Soil Bioengineering structures for the stabilisation of shallow soil movements. *Ecological Engineering*, 169, 106309
- [55] Tron, S., Perona, P., Gorla, L., Schwarz, M., Laio, F., Ridolfi, L. (2015): The signature of randomness in riparian plant root distributions. *Geophysical Research Letters*, 42 (17), pp. 7098–7106
- [56] Technische Regel ONR 24800 (2009): *Schutzbauwerke der Wildbachverbauung – Begriffe und ihre Definition sowie Klassifizierung*. Austrian Standards International – Standardisierung und Innovation, Wien
- [57] Bergmeister, K., Suda, J., Hübl, J., Rudolf-Miklau, F. (2009): *Schutzbauwerke gegen Wildbachgefahren*. Grundlagen, Entwurf und Bemessung, Beispiele. Ernst & Sohn, Berlin
- [58] Suda, J., Bergmeister, K. (2020): *Schutzbauwerke gegen Wildbachgefahren*. In: Bergmeister, K., Wörner, J.-D., Fingerloos, F. (Hrsg.), *Betonkalender 2020*, pp. 501–724; Ernst & Sohn Verlag, Berlin
- [59] Angerholzer, F. (1913): Über die Länge des Vorfeldes bei Querwerken in Wildbächen. *Centralblatt für das gesamte Forstwesen*, 39, pp. 504–509
- [60] Rudolf-Miklau, F., Sauermoser, S. (2011): *Handbuch Technischer Lawinenschutz*. Wilhelm Ernst & Sohn, Berlin
- [61] Tabler, R. (2003): *Controlling Blowing and Drifting Snow with Snow Fences and Road Design*. Final Report NCHRP Project 20-7 (147), Tabler & Associates, Laramie, Wyoming
- [62] von Carlowitz, H.C. (1713): *Sylvicultura Oeconomica*, Johann Friedrich Braun Verlag, Leipzig
- [63] WECD – World Commission on Environment and Development (1987): *Our common Future*. Oxford University Press
- [64] Norm SN EN ISO 14040/A1:2021 (2021): *Umweltmanagement – Ökobilanz – Grundsätze und Rahmenbedingungen (ISO 14040:2006/Amd 1:2020)*. Änderung A1. Schweizerische Normen-Vereinigung, Winterthur
- [65] Von der Thannen, M., Paratscha, R., Smutny, R., Strauss, A., Hufnagl, H., Lampalzer, T., Rauch, H.P. (2018): Zur Ökobilanz von Schutzbauwerken. Ein Fallbeispiel mit Varianten. In: *Wildbach- und Lawinenverbau*. Zeitschrift für Wildbach-, Lawinen-, Erosions-, und Steinschlagschutz. 82. Jg. H. 182, pp. 282–303. Bregenz/Verein der Diplomingenieure der Wildbach- und Lawinenverbauung Österreichs
- [66] Norm SN EN ISO 14044:2006 (2006): *Umweltmanagement – Ökobilanz – Anforderungen und Anleitungen (ISO 14044:2006)*. Schweizerische Normen-Vereinigung, Winterthur
- [67] Frischknecht, R., Jungbluth, N., Althaus, H.-J., Doka, G., Dones, R., Heck, T., Hellweg, S., Hischer, R., Nemecek, T., Rebitzer, G., Spielmann, M. (2005): The ecoinvent database: overview and methodological framework. *International Journal of Life Cycle Assessment*, Vol. 10, pp. 3–9
- [68] BAFU (2015): *Online Non-Road-Datenbank*, Bundesamt für Umwelt BAFU, <https://www.bafu.admin.ch/bafu/de/home/themen/luft/zustand/non-road-datenbank.html>, zuletzt abgerufen am 22.03.2018
- [69] BMLFUW (2006): *Richtlinien für die Wirtschaftlichkeitsuntersuchung und Priorisierung von Massnahmen der Wildbach- und Lawinenverbauung gemäss § 3 Abs. 2 Z 3 Wasserbautenförderungsgesetz 1985*. Teil I: *Kosten-Nutzen-Untersuchung (KNU) und standardisierte Nutzenuntersuchung*. Bundesministerium für Land- und Forstwirtschaft, Umwelt und Wasserwirtschaft, Sektion Forstwesen, Wien
- [70] von der Thannen, M., Hoerbinger, S., Paratscha, R., Smutny, R., Lampalzer, T., Strauss, A., Rauch, H.P. (2017): Development of an environmental life cycle assessment model for soil bioengineering constructions. *European Journal of Environmental and Civil Engineering*, <http://dx.doi.org/10.1080/19648189.2017.1369460>
- [71] von der Thannen, M., Hoerbinger, S., Muellebner, C., Biber, H., Rauch, H.P. (2021): Case study of a water bioengineering construction site in Austria. Ecological aspects and application of an environmental life cycle assessment model. *Int. J. Energy Environ., Eng.* 12, pp. 599–609. <https://doi.org/10.1007/s40095-021-00419-8>

# Titles available in the Lignatec series

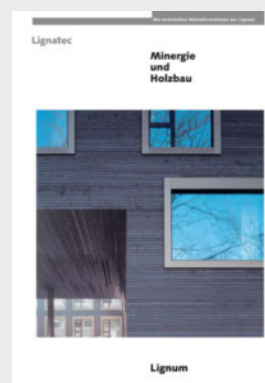
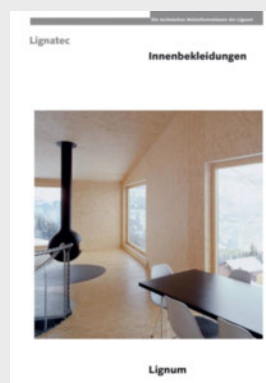
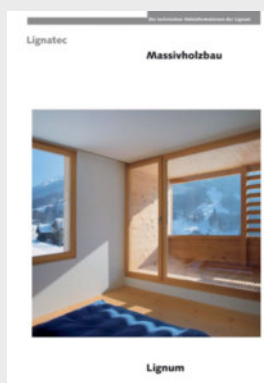
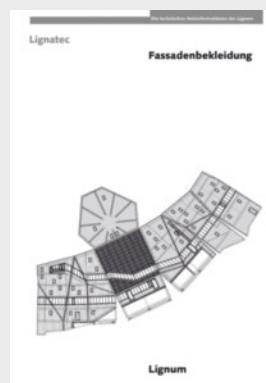
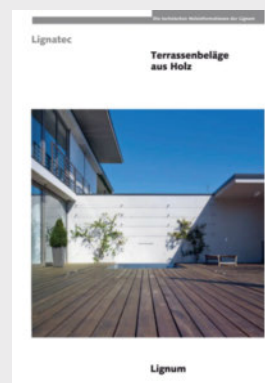
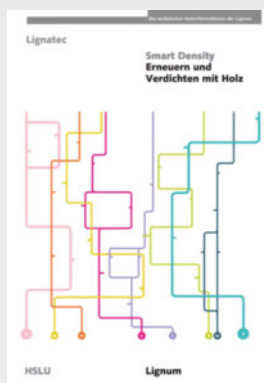
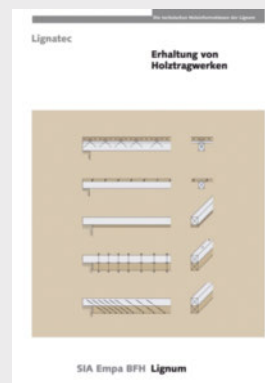
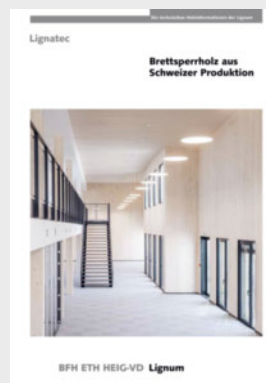
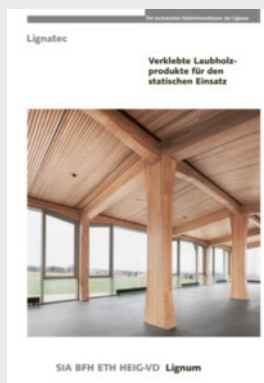

# Impressum

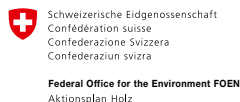

## Lignatec

Technical information on wood from Lignum

## Publisher

Lignum, Swiss Timber Industry, Zurich  
Sandra Burllet, managing director

## Key financial support

Swiss Federal Office for the Environment FOEN,  
Timber Action Plan

## Financial support

ecorisQ – int. association for natural hazard risk management  
Risk management foundation of cantonal building insurers

## Coordination

Gunther Ratsch, MSc Ing. BFH, Lignum, Zurich  
Hervé Bader, Dipl.-Ing. ETH, Fobatec  
Walter Krättli, Bsc Forstwirtschaft BFH, Fobatec  
Luuk Dorren, president of the ecorisQ association

## Translation

Translation Bureau for Environmental Sciences,  
Seeheim-Jugenheim

## Figure credits

Cover: Forst Aletsch (C. Pfammatter, Visp); 1, 7: WSL; 2: BABS;  
3: L. Dorren; 5, 6, 25, 26, 72: Castagnostyle; 8: Lindner Suisse;  
9, 12 left, 20, 23, 27, 29, 30, 31, 32: M. Schwarz;  
10: D. Polster; 12 right, 13, 14, 15, 19: Amt für Wald und  
Naturgefahren des Kantons Graubünden; 28, 42, 74: Forst  
Aletsch (C. Pfammatter); 31 left: Archiv Forstbetrieb Madrisa;  
33, 34, 35, 36, 37, 38 left, 39 D, 40, 41: J. Suda; 39 A, B, C, 43:  
Forsttechnischer Dienst für Wildbach- und Lawinverbauung;  
44, 45, 46, 47, 48, 50, 51, 52, 54, 55, 56, 57, 59, 60:  
S. Margreth; 49: WEU-AWN-NGA Bern; 53: P. Diener;  
24, 38 right, 67, 69, 71: Fobatec

## Pre-press

bido-graphic GmbH, Muttenz

## Administration/distribution

Lignum, Zurich

## Print

Kalt Medien AG, Zug

The Lignatec series provides information on technical issues regarding the use of wood as a construction and raw material. Lignatec is intended for planners, engineers, architects and manufacturers and processors of wood. Lignatec is increasingly being used at all levels of education and training. A loose-leaf binder can be obtained from Lignum.

Members of Lignum will receive a copy of each Lignatec publication free of charge. Further copies for members CHF 15.– Single copies for non-members CHF 35.– Loose-leaf binder (empty) CHF 10.– These prices are subject to change.

The copyright of this publication is owned by Lignum, Swiss Timber Industry, Zurich. Reproduction in whole or in part, presentation of content from the publication in the Internet, and feeding such content into databases is permitted only with the express written permission of the publisher.

## Disclaimer

This publication was produced with the utmost care and to the best of the publisher's, authors' and specialist editors' knowledge and judgement. They are not liable for any damage or loss which may occur through its use or application.

## LIGNUM

Holzwirtschaft Schweiz  
Mühlebachstrasse 8, 8008 Zurich  
Tel. 044 267 47 77, Fax 044 267 47 87  
info@lignum.ch  
www.lignum.ch

## Lignatec 34/2022

Using timber to counter natural hazards  
First published September 2022  
ISSN 1421-0320